

# SLIDING BEARINGS

Experience the difference



**SBS - Singa Bearings Solutions® PTE. LTD.**

 **Tel.: +65 6316 3850**  
**[www.sbs-bearings.com.sg](http://www.sbs-bearings.com.sg)**

**ISO 9001:2015 certified**

# Table of contents

---

<b>LUB-MET®</b> Solid bronze sliding bearing, solid lubricant, maintenance-free	6	<b>TEF-MET®/B</b> Wrapped composite sliding bearing, bronze/PTFE, maintenance-free	36
<b>BRO-MAS®</b> Solid turned bronze sliding bearing, heavy-maintenance	10	<b>NOX-MET®</b> Wrapped composite sliding bearing, stainless steel/PTFE, maintenance-free	42
<b>COM-KU®/D</b> Fibre-reinforced plastic composite sliding bearing, maintenance-free	13	<b>POM-MET®</b> Wrapped composite sliding bearing, steel/acetal resin (POM), lubrication pockets, low-maintenance	48
<b>COM-KU®/M</b> Composite sliding bearing, specially woven PTFE and synthetic fibre sliding layer, maintenance-free	16	<b>BRO-MET®</b> Wrapped bronze sliding bearing, lubrication pockets, low-maintenance	52
<b>GAP-MET®/M</b> Solid bronze sliding bearing, high-compressed with evenly applied lubricant, manufactured employing sintering technique, maintenance-free	19	<b>BRO-MET®/L</b> Wrapped bronze sliding bearing, perforations, low-maintenance	52
<b>GAP-MET®/S</b> Wrapped sliding bearing, steel/graphite impregnated bronze, maintenance-free	19	<b>BIV-MET®</b> Wrapped composite sliding bearing, steel/bronze, lubrication pockets, low-maintenance	57
<b>FER-MAS®</b> Turned steel sliding bearing, heavy-maintenance	23	<b>BRO-LUB®</b> Wrapped bronze sliding bearing, solid lubricant, maintenance-free	61
<b>FER-MET®</b> Wrapped steel bearing, inner and outer tension bushing, heavy-maintenance	26	<b>BIV-LUB®</b> Wrapped composite sliding bearing, steel/bronze, solid lubricant, maintenance-free	61
<b>FER-MAN®246</b> Low maintenance impact-resistance steel sliding bearing with very high surface hardness	29	<b>SIB-MET®</b> Sintered bronze sliding bearing, oil soaked, self-lubricating	65
<b>FER-MAN®259</b> Maintenance-free steel bushing, impact resistant, high breaking strength, able to absorb shock loadings	29	<b>COM-KU®/D SPHERICALS</b> Spherical plain bearing, stainless steel, with COM-KU®/D sliding layer, maintenance-free and corrosion-free	71
<b>FLO-MAS®</b> Rubber lined bearing, water lubricated	33	<b>LUB-MET® SPHERICALS</b> Spherical plain bearing, LUB-MET® with stainless steel, maintenance-free and corrosion-free	75
<b>TEF-MET®</b> Wrapped composite dry sliding bearing, steel/PTFE, maintenance-free	36	<b>SPHERICAL PLAIN BEARINGS &amp; ROD ENDS</b> Ball joint ends - spherical plain bearings, maintenance-free and heavy-maintenance	81

# Our materials at a glance



**LUB-MET®**  
page 6



**BRO-MAS®**  
page 10



**COM-KU®/D**  
page 13



**COM-KU®/M**  
page 16



**GAP-MET®/M**  
page 19



**GAP-MET®/S**  
page 19



**FER-MAS®**  
page 23



**FER-MET®**  
page 26



**FER-MAN®246**  
page 29



**FER-MAN®259**  
page 29



**FLO-MAS®**  
page 33



**TEF-MET®**  
page 36



**TEF-MET®/B**  
page 36



**NOX-MET®**  
page 42



**POM-MET®**  
page 48



**BRO-MET®**  
page 52



**BRO-MET®/L**  
page 52



**BIV-MET®**  
page 57



**BRO-LUB®**  
page 61



**BIV-LUB®**  
page 61



**SIB-MET®**  
page 65



**COM-KU®/D SPHERICALS**  
page 71



**LUB-MET® SPHERICALS**  
page 75



**SPHERICAL PLAIN BEARINGS  
& ROD ENDS**  
page 81

## About SBS

SBS established itself from a German family business with over 35 years of experience in sliding bearing technology! The company deals exclusively with the distribution and production of pre-finished sliding bearings and sliding bearing components. SBS puts high quality service into practice – to exceed our customers' expectations is our top priority.

Best quality – quick availability – keen pricing – this is what customers demand from a qualified supplier. Benefit from our quality, service and expert knowledge for the success of your products!

SBS has established itself as a business partner of well-known national and international companies for deck machinery, oil rigs, drilling applications and mooring equipment in the Marine and Off-Shore Industry. We are also catering to clients in the engine, vehicle construction, crane, hydropower and similar industries.

SBS has made its name to be a specialist for custom made parts and designs according to our client's requirements and drawings. We are able to produce these special items in many different materials such as Bronze and COM-KU®/D at very short notice.

## Technical information

### $p_v$ -value

$p_v$ -value is the product of bearing contact pressure  $p$  and relative velocity  $V$  between the shaft and the bearing. It is an essential factor to consider when selecting/designing a sliding bearing, as it has a substantial impact on the bearing life.

$p_v$ -value specified in the catalogue indicates the allowable  $p_v$ -value, which should be designed with a margin of safety.

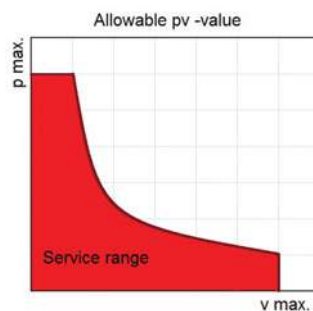

### $p_v$ -value and operating temperature

When designing a bearing, it is important to consider below requirements, depending on the operational temperature. The temperature range indicated in this catalogue is obtained from the material properties and the geometry of the bearings.

#### High temperature operation

- Due to deteriorating anti-friction properties with increasing temperature, the bearing design should be set at a lower  $p_v$ -value
- Decrease in clearance between the bearing and the shaft due to dimensional expansion of the ID should be taken into account
- Reduction in the bearing material hardness should be considered
- Due to decrease in interference between the bearing and the housing (caused by stress relaxation of the softened material), set-screws should be considered to prevent rotation of bearing in its housing

#### Low temperature operation

- Decrease in clearance due to dimensional shrinkage of the ID should be considered
- Decline in interference between the housing and the bearing to be taken into account
- Effects of low temperature on brittleness and impact strength of the bearing material are to be analysed
- In comparison with metallic bearings, bearings made of plastics (like COM-KU®/D) are more susceptible to heat effects (i.e. have higher coefficient of thermal expansion), due to their lower melting point.

#### $p_v$ -value and intervals of operation

- Generally, intermittent operation is a favourable operational condition for sliding bearings. During stoppage between operation cycles, the sliding surface cools down. However, in case of insufficient grease lubrication, the frequent resumption and termination of rotation leads to faster wear of the sliding surface.
- When using self-lubricating (maintenance-free) bearings, the lubricant film formed on the sliding surface prevents abrupt performance drop, even when there is no sufficient lubrication.

#### Counter material selection

- The bearing's performance is greatly dependant on the surface it slides against (counter surface). Not only is the right counter material important but also its hardness, the surface roughness and possible surface treatment processes.
- The counter materials specifications are influenced by bearing material, resulting contact pressures, sliding speed, environmental conditions (i.e. sea-water).

## Counter Material Selection Guidelines

Bearing	Contact pressure N/mm <sup>2</sup>	Material	Hardness	Surface roughness R <sub>a</sub>
Metallic bearings	up to 24.5	Carbon steel for machine structure alloy steel (C45, 42CrMo4) In corrosive environment: corrosion resistant steel, (X20Cr13, X22CrNi17(AISI431)) In sea-water: (Super)Duplex grades or Inconel 625	HB150 or over	Less than R <sub>a</sub> 1.6
	24.5 - 49.0	Surface hardening treatment such as induction hardening and carburizing should be implemented for the materials described above.	HB250 or over	
	49.0 - 98.0	In addition to surface hardening treatment as above, additional surface treatment such as nitriding treatment and hard chrome plating should be implemented.	HRC50 or over	
Plastic and multi-layer bearings	up to 49.0	Carbon steel for machine structure alloy steel (S45C, SNC415, SCM435) In corrosive and sea-water environment: corrosion resistant steel, (X2CrNiMo17-12-2 (AISI316); X5CrNi1810 (AISI304))	HB120 or over	Less than R <sub>a</sub> 0.8
	49.0 - 98.0	Surface treatment such as induction hardening, quenching by carburizing and hard chrome plating should be implemented for the materials described above.	HRC45 or over	

## Foreign particle contamination

In comparison with rolling-element bearings, self-lubricating sliding bearings are much less sensitive to contamination by foreign particles. Nevertheless, the bearing performance and life-span may be affected. The following procedures are recommended:

- Implementation of dust seals at both sides of the bearing and fill bearing area with grease
- Occasional greasing of the bearing, to discharge of foreign particles and prevent contamination
- Surface hardening treatment of the shaft

## Bearing Design

### Length

For general use, the ratio of the bearing length and ID is:  $L/D = 0.5$  to  $2.0$ . For applications with high loads, uneven contact or high rotational speed, the ratio advised is:  $L/D = 0.8$  to  $1.0$ .

The properties improving with larger ratio: oil film formation capability, vibration damping

Advantage of smaller ratio: safety margin for eccentric load, space saving, discharge of particles, heat radiation

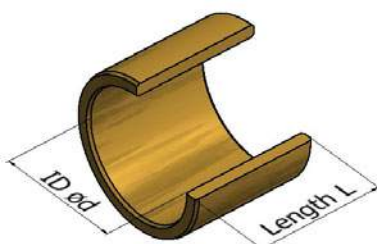

### Wall thickness

- The following table indicates the guidelines for wall thickness for different types of bearings. To achieve more compact designs, wall thickness could be reduced to certain extent.

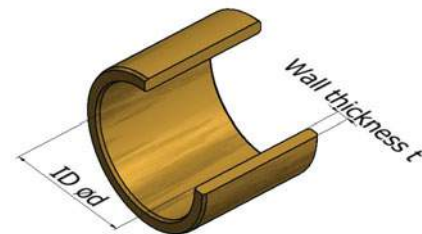

### Wall Thickness Guidelines

ID	ø10	ø20	ø50	ø100	ø300
Bearing type	(mm)	(mm)	(mm)	(mm)	(mm)
LUB-MET® BRO-MAS® COM-KU®/D	2-3	2-4	5-7.5	7.5-15	20-25
Plastic material (molded)	1-2	1-3	3-5	5-10	20-30
Wrapped bushes (i.e. TEF-MET®)	1	1.5	2-2.5	2.5	2.5

### Chamfering

In order to simplify the mounting of a sliding bearing and to avoid stress concentration, chamfers should be designed at both ends of the bearing. The general guidelines are indicated in the table below:

#### Chamfering Guidelines

Bearing ID (mm)	Chamfer size of ID and OD (mm)
Up to 30	0.5x45°
to ø80	1.0x45°
ø80 to ø200	1.5x45°
ø200 to ø300	2.0x45°
Over ø300	2.5x45°

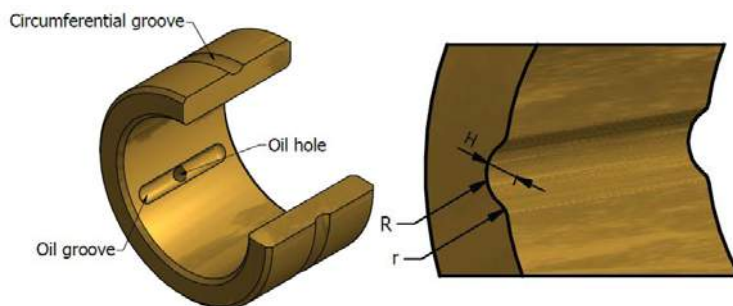

#### Standard Dimensions For Lubrication Grooves

Bearing ID (mm)	R (groove) (mm)	r (chamfer) (mm)	H (depth of groove) (mm)	Number of grooves
30 or less	1.5	1.5	1.2	1 to 2
30 to 50	1.6	1.6	1.3	1 to 3
50 to 80	1.7	1.7	1.4	1 to 4
80 to 120	1.8	1.8	1.5	1 to 5
120 to 180	1.9	1.9	1.6	1 to 6
180 to 250	5.0	5.0	6.0	5
250 to 315	6.0	5.1	6.1	6
315 to 400	7.0	5.2	6.2	7
400 to 500	8.0	5.3	6.3	8

### Lubrication

Occasional lubrication increases the life of a bearing by improving the following properties:

- Increase of allowable  $p_v$ -value
- Decrease of wear due to improvement of friction coefficient
- Cooling effect
- Discharge of foreign and wear particles
- Prevention of shaft corrosion
- Improved reliability

Recommended lubricants:

Grease: Li-based multi-purpose grease (with consistency of NLG 2-0)

\* If operating temperature is above 150°C, the grease with polyuria or bentonite thickeners is recommended.

#### Design of lubrication hole and grooves

- Length of lubrication groove should be 70-80% of bearing width, and all edges should be rounded
- A lubrication hole should be located inside the lubrication groove
- If lubricant is fed from the housing, a groove on the OD should be added to transport the lubricant to the inside of the bearing.

## Installation into housing

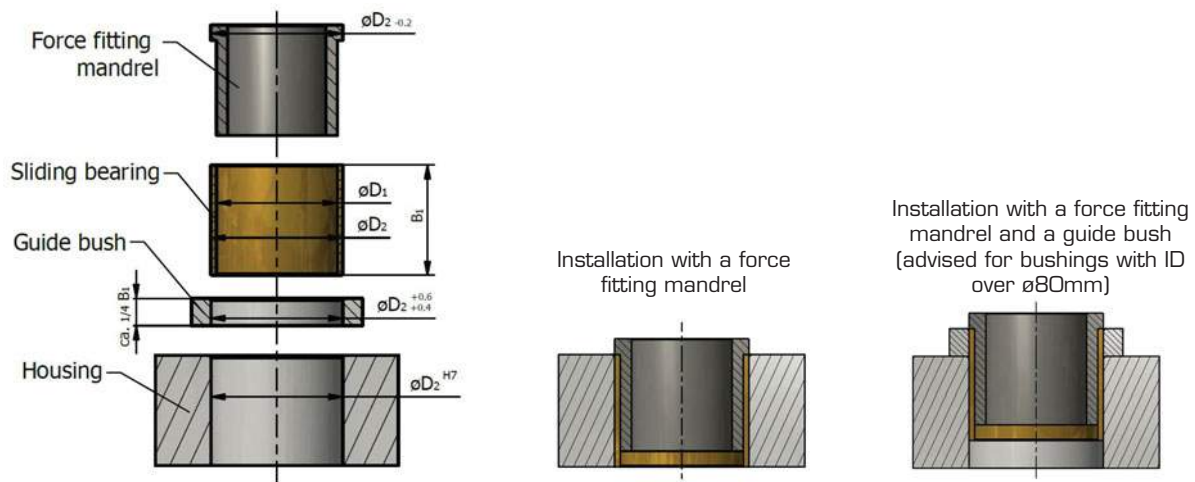

### Press fitting

Press fitting is a common method of installation, by means of a hydraulic press or a support mandrel.

### Freeze fitting

Freeze fitting (shrink fit) is a recommended installation method to avoid the risk of damaging the bearing during installation. In comparison to press fitting, shrink fitting requires less tooling and guarantees a higher alignment accuracy. It is strongly advised for solid bushings with ID over ø150mm.

There are two agents for the cooling procedure:

1. Dry – ice
  - Temperature: - 70 to - 80°C
  - cooling time of bearings approx. 2 hours
  - Easy to handle
  - Excellent availability (inexpensive for small bearing quantities)
2. Liquid nitrogen
  - Temperature: - 196°C
  - cooling time of bearings approx. 10 min
  - Higher precautions when handling
  - Good availability (cost competitive if large number of bearings need to be installed)
  - Must not be used to shrink LUB-MET® bearings

Please contact SBS for the respective detailed installation procedure.

### Calculation of shrinkage

The shrinkage (s) is calculated using the following equation

$$s = 0.8 \times \alpha \times (T_0 - T_1) \times D \text{ (mm)}$$

- outer diameter of bearing : D (mm)
- coefficient of thermal expansion of bearing :  $\alpha$  ( $10^{-5}/^{\circ}\text{C}$ )
- atmospheric temperature :  $T_0$  ( $^{\circ}\text{C}$ )
- cooling temperature :  $T_1$  ( $^{\circ}\text{C}$ )

### Clearance-fit design

Self-lubricating bearings require larger clearance fit than conventional sliding bearings under hydrodynamic lubrication, due to larger thickness of solid lubricant layer and higher generated frictional heat.

For applications which might cause swelling, further clearance correction is required.

### Fittings for high operating temperature

When the operating temperature of a metallic bushing is over 100°C, thermal expansion coefficient of shaft material should be taken into account. The thermal expansion distance is to be added to the tolerances of ID at room temperature (20°C).  
Thermal expansion distance = Thermal expansion coefficient of shaft material x Shaft D x (operating  $t^{\circ}$  - room  $t^{\circ}$ )

### Coefficient of thermal linear expansion for typical shaft materials

Shaft material	Coefficient of thermal expansion
Soft steel	$1.12 \times 10^{-5}/^{\circ}\text{C}$ (20 to 300°C)
Ni-Cr Steel	$1.29 \times 10^{-5}/^{\circ}\text{C}$ (20 to 300°C)
X22CrNi17 (AISI431)	$1.21 \times 10^{-5}/^{\circ}\text{C}$ (20 to 300°C)
X2CrNiMo17-12-2 (AISI316)	$1.62 \times 10^{-5}/^{\circ}\text{C}$ (20 to 300°C)

When the bushing is cooled down to room temperature after operating in high temperature, stress relaxation may cause decrease in interference. To prevent sliding at the OD, set-screws are strongly recommended.

# LUB-MET®



solid bronze sliding bearing, solid lubricant, maintenance-free



Solid bronze sliding bearing with solid lubricant inserts •  
Maintenance-free



	<p><b>PROPERTIES</b></p> <p>For high operational demands (also impact load), oscillating movements, wear-resistant, unsusceptible to dirt, corrosion resistant, long life capability. For more details, see <b>Bearing properties</b> (page 8).</p>
	<p><b>MATERIAL PROPERTIES</b></p> <p>Standard material CuZn25Al5 / ASTM C86300. For additional metal alloys, see LUB-MET® material list (page 8).</p>
LUB - MET®	
Cylindrical bushing	
LMZ	
	<p><b>SOLID LUBRICANTS</b></p> <p>Our solid lubricants are high density compounds of graphite, PTFE and metals. Lubricants are oriented to motion direction. Direction to be specified with order.</p>
Flange bushing	
LMB	
	<p><b>TOLERANCE DETAILS</b></p> <p>Housing Ø H7 Bushing Inner Ø after mounting Standard tolerances: r6/E7 Different tolerances on customer request.</p> <p>Shaft tolerance f7 / h6</p>
Thrust washer	
LMA	
	<p><b>SHAFT MATERIAL</b></p> <p>The hardness difference to the bearing should be at least 100HB, preferably hardened and ground to size. Surface roughness Ra 0.2 – 0.8 µm</p>
Strips	
LMS	
	<p><b>MOUNTING ADVICE</b></p> <p>Housing Mounting chamfer, min. 1,5 mm x 15-45° Shaft Mounting chamfer, 5 mm x 15°, edges rounded Force fitting mandrel Using a force fitting mandrel is advisable. Grease lubrication of outer surface may be necessary before assembly. Freeze fitting For diameter &gt; 130mm, the use of dry ice is advisable</p>
	<p><b>MAINTENANCE</b></p> <p>LUB-MET® is a maintenance-free sliding bearing, but primary lubrication is necessary! Therefore, an ageing resistant lithium-stiffened grease should be used.</p>

We produce all special designs at short notice! Custom sizes are manufactured in a short time!

## MATERIAL LIST

Material description				Analysis	Physical properties					Application
DIN Alloy No.	ASTM Alloy No.	Scandinavian Alloy No.	British Alloy No.	Chemical Composition	Yield Strength	Tensile Strength	Elongation	E-module	Hardness	
				%	N/mm <sup>2</sup>	N/mm <sup>2</sup>	%	x 10 <sup>3</sup>	HB	
CuSn7ZnPb <sub>1</sub> CuSn7ZnPb <sub>2</sub> CuSn7ZnPb <sub>3</sub>	C932 00	JM1	1400 LG2	Cu 81-85 Sn 5-6 Zn 3-5 Pb 5-7 Ni 2 max Sb 3,3 max	120 130 120	240 270 270	15 13 16	106 106 106	65 75 70	Medium-hard bearing alloy Good anti-friction properties Seawater resistant Applicable for light edgeloads
CuSn12Pb <sub>1</sub> CuSn12Pb <sub>2</sub> CuSn12Pb <sub>3</sub>	C925 00	JM3	1400 PB2	Cu 84-88 Sn 11-13 Pb 1-2 Ni 2 max Sb 0,2 max P 0,2 max	140 150 140	260 280 280	10 5 7	112 112 112	80 90 85	Material for high loads Seawater resistant
CuAl10Ni <sub>1</sub> CuAl10Ni <sub>2</sub> CuAl10Ni <sub>3</sub>	C955 00	JM7	1400 AB2	Cu 75 min Al 8,5-11 Ni 2-8,5 Fe 3,5-5,5 Mn 3,3 max	270 300 300	600 700 800	12 13 13	122 122 122	140 160 160	Hard Ni-Al bronze Very high strength Excellent wear resistance Corrosion-resistant Seawater resistant High temperature strength
CuZn25Al5 <sub>1</sub> CuZn25Al5 <sub>2</sub> CuZn25Al5 <sub>3</sub>	C863 00	JM18		Cu 60-67 Al 3-7 Fe 1,5-4 Mn 2,5-5 Zn balance Ni 3 max	450 480 480	750 750 750	8 8 5	115 115 115	200 220 220	Water resistant High strength bearing alloy High fatigue resistance Not applicable for seawater applications

1 Sand casting   2 Centrifugal casting   3 Continuous casting

## BEARING PROPERTIES \*

Bronze Material	Solid Lubricant	p static (N/mm <sup>2</sup> )	p dynamic (N/mm <sup>2</sup> )	Friction dry	Friction wet	v (m/s) max.	max p <sub>v</sub> value N/mm <sup>2</sup> x m/s	Temp. °C max.	Shaft Hardness HB (min)	Shaft Finish R <sub>a</sub> (µm)
CuSn7ZnPb	SL 4	80	40	0.11 - 0.13	0.07 - 0.12	0.4	1.2	80	180	0.2 - 0.8
	SL 1	80	30	0.12 - 0.14	Not available	0.5	1.0	250		
CuSn12PB	SL 4	100	70	0.11 - 0.13	0.07 - 0.12	0.4	2.0	80	180	0.2 - 0.8
	SL 1	100	25	0.12 - 0.14	Not available	0.15	1.6	250		
CuAl10Ni	SL 4	150	90	0.13 - 0.15	0.07 - 0.12	0.4	1.5	80	300	0.2 - 0.8
	SL 1	150	80	0.14 - 0.16	Not available	0.4	1.5	350		
CuZn25Al5	SL 4	150	100	0.13 - 0.15	0.07 - 0.12	0.4	1.5	80	300	0.2 - 0.8
	SL 1	150	90	0.14 - 0.16	Not available	0.15	1.0	300		

\* The above stated bearings properties are valid for optimal operating conditions. Through changes of the application conditions as e.g. higher sliding speed or shaft roughness, these values are subject to change.

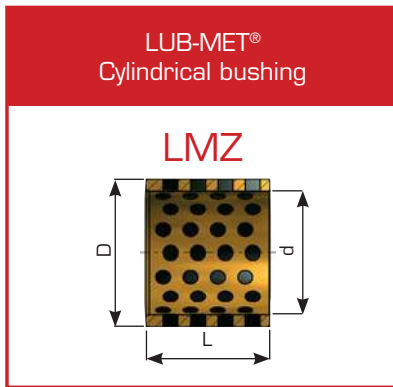

LM	Z	50	65	70
Type (LUB-MET®)	Geometry (Cylindrical bushing)	Inner diameter 50 mm (d)	Outer diameter 65 mm (D)	Length 70 mm (L)

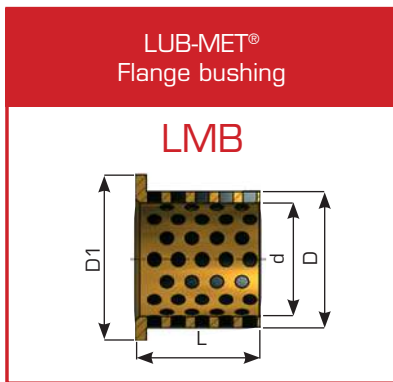

LM	B	50	65	70
Type (LUB-MET®)	Geometry (Flange bushing)	Inner diameter 50 mm (d)	Outer diameter 65 mm (D)	Length 70 mm (L)

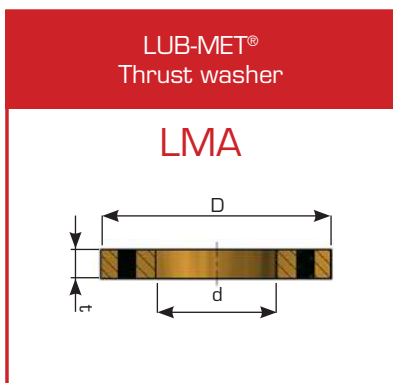

LM	A	30	60	05
Type (LUB-MET®)	Geometry (Thrust washer)	Inner diameter 30 mm (d)	Outer diameter 60 mm (D)	Thickness 5 mm (t)

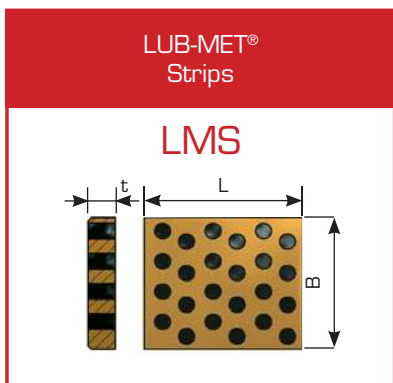

LM	S	30	70	10
Type (LUB-MET®)	Geometry (Strip)	Width 30 mm (B)	Length 70 mm (L)	Thickness 10 mm (t)

All sizes and measurements can be produced to customer's specification.

# BRO-MAS®



solid turned bronze sliding bearing, heavy-maintenance

Solid turned bronze sliding bearing • DIN 1850 / ISO 4379 •  
Various alloys



<b>BRO-MAS®</b>
<b>Cylindrical bushing</b>
<b>BSZ</b>
<b>Flange bushing</b>
<b>BSB</b>
<b>Thrust washer</b>
<b>BSA</b>
<b>Strips</b>
<b>BSS</b>

## PROPERTIES

Maintenance-bound sliding bearing, suitable for operation in contaminated environment, good corrosion resistance, unsusceptible to impact load.

## MATERIALS

Standard material

Standard material CuSn12

## MATERIAL PROPERTIES

Specific load capacity static	≤ 150 [ N/mm <sup>2</sup> ]
Specific load capacity dynamic	≤ 60 [ N/mm <sup>2</sup> ]
Sliding speed	< 10 [ m/s ] depends on lubrication - strain
Temperature strain	-40 – +150 [ °C ]

## TOLERANCE DETAILS

Housing Ø	According to customer's preference.
Bushing Inner Ø after mounting	According to customer's preference.
Shaft tolerance	According to customer's preference.

## SHAFT MATERIAL

Hardened steel, surface roughness  $R_a < 0.8 \mu\text{m}$

## MOUNTING ADVICE

Housing	Mounting chamfer, min. 1,5 mm x 15-45°
Shaft	Mounting chamfer, 5 mm x 15°, edges rounded
Freeze fitting	For diameter > 130mm, dry ice or liquid nitrogen can be used

## MAINTENANCE

Oil or grease lubrication is necessary.  
Lubrication groove systems and greater clearance between shaft and bushing will reduce maintenance to a minimum.

DIN Alloy No.	ASTM Alloy No.	Scandinavian Alloy No.	British Alloy No.	Yield Strength	Tensile Strength	Elongation	Hardness
				N/mm <sup>2</sup>	N/mm <sup>2</sup>	%	HB
CuSn7ZnPb (RG7)	C93200	JM1	1400 LG 2	130	270	13	75
CuSn10	C90700	JM2	1400 PB1	140	290	13	80
CuSn12	C90800	JM3	1400 PB2	150	280	5	95
CuPb15Sn	C93800	JM4	1400, LB1	100	210	7	65
CuPb10Sn	C93700	JM5	1400, LB2	100	220	8	70
CuAl10Ni	C95500	JM7	1400 AB2	300	680	13	160
CuSn10Zn (RG10)	SAE 62	JM12	1400 G1-C (BC3)	140	260	7	80
CuZn25Al5	C86300	JM18		480	750	8	220
CuSn5ZnPb (RG 5)	C83600	SS5204	1400 LG2 (BC6)	90	250	13	65

We produce all special designs at short notice!

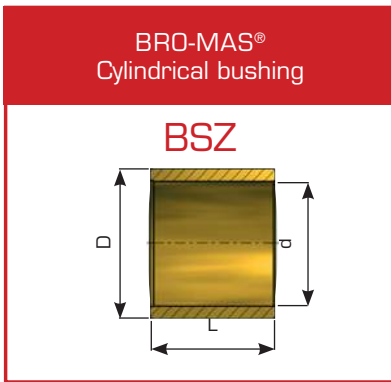

BS	Z	50	65	70
Type (BRO-MAS®)	Geometry (Cylindrical bushing)	Inner diameter 50 mm (d)	Outer diameter 65 mm (D)	Length 70 mm (L)

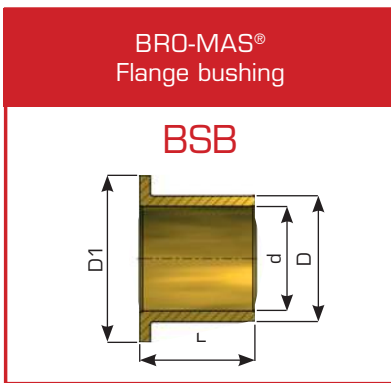

BS	B	50	65	70
Type (BRO-MAS®)	Geometry (Flange bushing)	Inner diameter 50 mm (d)	Outer diameter 65 mm (D)	Length 70 mm (L)

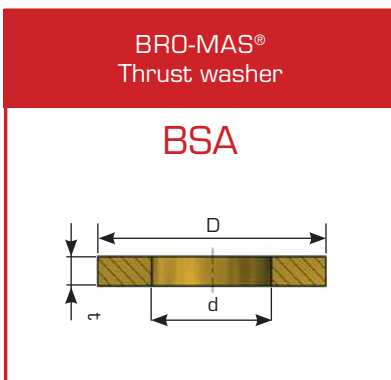

BS	A	30	60	05
Type (BRO-MAS®)	Geometry (Thrust washer)	Inner diameter 30 mm (d)	Outer diameter 60 mm (D)	Thickness 5 mm (t)

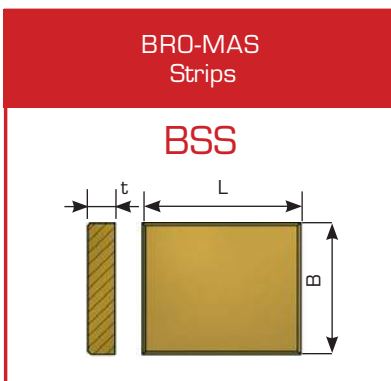

BS	S	30	70	10
Type (BRO-MAS®)	Geometry (Strip)	Width 30 mm (B)	Length 70 mm (L)	Thickness 10 mm (t)

All sizes and measurements can be produced to customer's specification.

# COM-KU<sup>®</sup>/D



fibre-reinforced plastic composite sliding bearing, maintenance-free

Fibre-reinforced plastic composite sliding bearing •  
Maintenance-free



## PROPERTIES

Good sliding properties, suitable for high load capacity (as well as impact and edge loads), good chemical resistance, long life span, good damping features. Recommended as replacement for lubricated bushings e.g. bronze. Maintenance-free.

## MATERIAL

Compound plastic with friction modifiers, produced in a winding technique.

## MATERIAL PROPERTIES\*

	Unit	D400	D402	D406
Compressive strength (Flatwise)	[ N/mm <sup>2</sup> ]	>320	>300	>280
Compressive strength (Edgewise)	[ N/mm <sup>2</sup> ]	>100	>90	>90
Safe Maximum Static Load	[ N/mm <sup>2</sup> ]	<150	<140	<120
Safe Maximum Dynamic Load	[ N/mm <sup>2</sup> ]	<60	<60	<50
Flexural Strength	[ N/mm <sup>2</sup> ]	>80	>70	>70
Shear strength	[ N/mm <sup>2</sup> ]	>90	>80	>80
Tensile strength	[ N/mm <sup>2</sup> ]	>65	>60	>60
Tensile Modulus	[ N/mm <sup>2</sup> ]	3200	3200	3200
Coefficient of friction (dry)		0.13 – 0.15	0.10 – 0.12	0.06 – 0.09
Coefficient of friction (lubricated H2O / Oil)	[ N/mm <sup>2</sup> ]	0.02 – 0.04	0.02 – 0.04	0.01 – 0.03
Hardness - Rockwell M		80	80	80
Density	gms/cc	1.3	1.3	1.3
Water Absorption (volumetric)	%	<0.1	<0.1	<0.1
Short term temperature (min./max.)	°C	-70 / 100	-70 / 100	-70 / 100
Temperature range (long term)	°C	-30 to 75	-30 to 75	-30 to 75
Colour		Dark grey	Yellow	Light grey

Other material grades e.g. for high-temperature or extreme wear-resistance are available on request. Existing material grades can be fine-tuned to specific application requirements.

## TOLERANCE DETAILS

Housing Ø	H7
Bushing Inner Ø after mounting* *	Specified by the customer

## MOUNTING ADVICE

Housing	Mounting chamfer, min. 1.5 mm x 15-45°
Shaft	Mounting chamfer, 5 mm x 15°, edges rounded
Force fitting mandrel	Application of an adequate force fitting mandrel is advisable For diameter > 130mm, use of liquid nitrogen is preferred
Freeze fitting	

## MAINTENANCE

No maintenance required if shaft is corrosion resistant. Otherwise, periodical greasing of the shaft is advised.

COM-KU®/D is a maintenance-free composite sliding bearing.

\* The above stated material properties are valid for optimal operating conditions. Through changes of the application conditions e.g. higher sliding speed or strain, these values are subject to change.

\*\* Please note, that fitting dimensions and tolerances have to be "plastic-tailored" considering the larger expansion coefficient compared to metal sliding bearings. As a result, larger tolerance ranges and clearances can occur.

We produce all special designs at short notice!



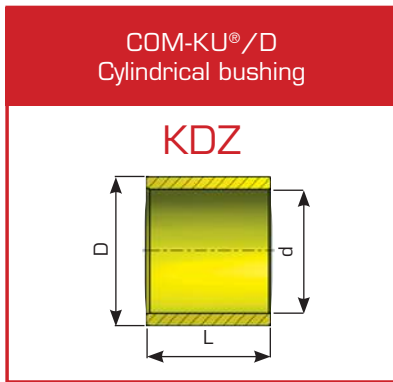

KD	Z	50	65	70
Type (COM-KU®/D)	Geometry (Cylindrical bushing)	Inner diameter 50 mm (d)	Outer diameter 65 mm (D)	Length 70 mm (L)

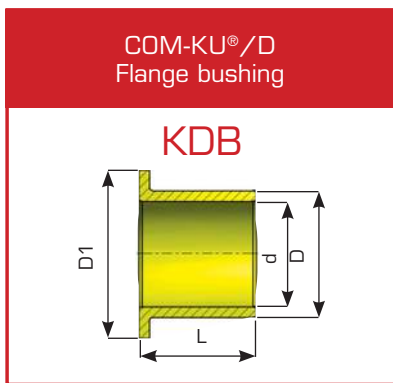

KD	B	50	65	70
Type (COM-KU®/D)	Geometry (Flange bushing)	Inner diameter 50 mm (d)	Outer diameter 65 mm (D)	Length 70 mm (L)

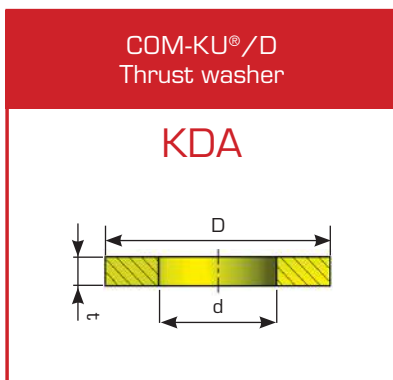

KD	A	30	60	05
Type (COM-KU®/D)	Geometry (Thrust washer)	Inner diameter 30 mm (d)	Outer diameter 60 mm (D)	Thickness 5 mm (t)

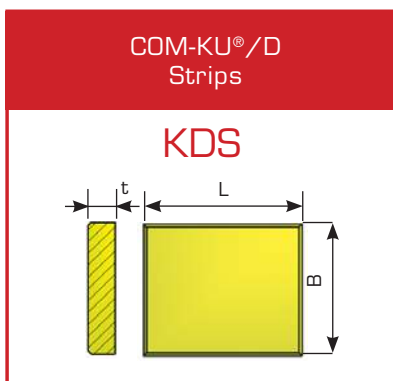

KD	S	30	70	10
Type (COM-KU®/D)	Geometry (Strip)	Width 30 mm (B)	Length 70 mm (L)	Thickness 10 mm (t)

All sizes and measurements can be produced to customer's specification.

# COM-KU<sup>®</sup>/M



composite sliding Bearing, specially woven PTFE and  
synthetic fibre sliding layer, maintenance-free

Composite Bearing • Specially woven PTFE and synthetic fibre sliding layer •  
Maintenance-free

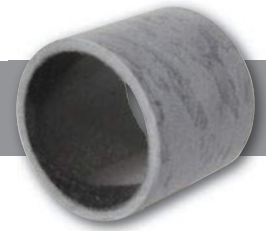

**COM-KU®/M**

**Cylindrical bushing**

**KMZ**

## PROPERTIES

Ideal for high load. Excellent mechanical properties and fatigue strength. Suitable for rotating, oscillating and reciprocating moments under slow speed. Robust sliding layer with low-friction and very good wear behaviour.

## MATERIALS

Filament wound fiberglass backing + PTFE fibre sliding layer

## PHYSICAL PROPERTIES

Maximum load static [N/mm <sup>2</sup> ]	210
Maximum load dynamic [N/mm <sup>2</sup> ]	140
Min. Hardness [HRC]	25
Density [g/cm <sup>3</sup> ]	2.03
Working temperature [°C]	-100 – +160
Maximum sliding speed [m/s]	0.1
p <sub>v</sub> - value [N/mm <sup>2</sup> x m/s]	2.8
Coefficient of friction, dry μ [dry]	0.03 – 0.15
Water adsorption, volumetric [%]	0.11

## TOLERANCE DETAILS

Housing Ø	H7
Bushing Inner Ø after mounting	Depends on wall thickness of the bushing
Shaft tolerance	h7/h8

## SHAFT MATERIAL

Steel, hardness > 200HB, surface roughness R<sub>a</sub> < 0.8 μm

## MOUNTING ADVICE

Housing	Mounting chamfer, min. 1.5 mm x 15-45°
Shaft	Mounting chamfer, 5 mm x 15°, edges rounded
Force fitting mandrel	The application of an adequate force fitting mandrel is advisable.

## MAINTENANCE

No maintenance required, if shaft is corrosion resistant.  
Otherwise, periodical greasing of shaft is advised.

We produce all special designs at short notice! Only cylindrical bushings are standard fabrication. Variable wall thickness possible.  
Inch sizes available!

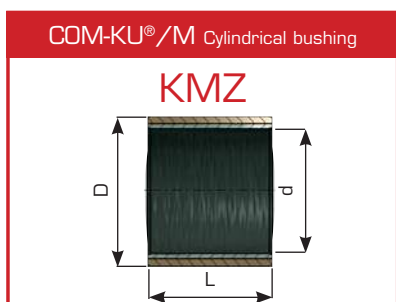

	L	20	30	40	50	55	60	70	80	100	120	150
d	D											
12	17	121720										
15	20	152020										
16	21	162120										
18	23	182320										
20	25	202520										
22	27	222720										
25	30		253030									
28	34		283430									
30	36		303630									
35	41			354140								
40	48			404840								
45	53			455340								
50	58				505850							
55	63					556355						
60	70						607060					
65	75						657560					
70	80							708070				
75	85							758570				
80	90								809080			
85	95								859580			
90	105								9010580			
95	110								9511080			
100	115									100115100		
110	125									110125100		
120	135										120135120	
130	145										130145120	
140	155											140155150
150	165											150165150

# GAP-MET®/M



solid bronze sliding bearing, high-compressed with evenly applied lubricant,  
manufactured employing sintering technique, maintenance-free

# GAP-MET®/S



Wrapped sliding bearing, steel/GRAPHITE IMPREGNATED BRONZE,  
maintenance-free

Self-lubricating sliding bearing • High-compressed with evenly applied solid lubricant  
 Manufactured employing sintering technique • Maintenance-free



	<b>PROPERTIES</b>	High load capacity and stability, for all slow movements, unsusceptible to dirt, no moisture absorption, good chemical resistance, very good temperature resistance, can be reworked mechanically.
<b>GAP-MET®/M</b>	<b>MATERIALS</b>	
<b>Cylindrical bushing</b>	Base material*	Bronze with smoothly dispersed graphite incorporated in the matrix
<b>GAZ/M</b>	Sliding surface **	CuSn / CuSnPb
	Running-in layer	Graphite film (optional)
<b>Flange bushing</b>	<b>MATERIAL PROPERTIES***</b>	
<b>GAB/M</b>	Specific load capacity static	≤ 250 [ N/mm <sup>2</sup> ]
	Specific load capacity dynamic	≤ 130 [ N/mm <sup>2</sup> ]
	Sliding speed	≤ 0.5 [ m/s ] dry
	Friction value	0,10 – 0,20 [ μ ]
	Temperature strain	-50 – +350 (+650 possible) [ °C ]
	Max. p <sub>v</sub> - value	1.5 [ N/mm <sup>2</sup> x m/s ] dry
<b>Thrust washer</b>	<b>TOLERANCE DETAILS</b>	
<b>GAA/M</b>	Housing Ø	H7
	Bushing Inner Ø after mounting	To customer's specification (D8 / H8 / H9)
	Shaft tolerance	To be specified by customer (d7 / e7 / f7 / h7)
<b>Strips</b>	<b>SHAFT MATERIAL</b>	Hardened steel > 180HB, surface roughness R <sub>a</sub> ≤ 0.8 μm
<b>GAS/M</b>	<b>MOUNTING ADVICE</b>	
	Housing	Mounting chamfer, min. 1.5 mm x 15-45°
	Shaft	Mounting chamfer, 5 mm x 15°, edges rounded
	Force fitting mandrel	Application of an adequate force fitting mandrel is advisable. Grease lubrication of the outer surface may be necessary when mounting.
	Freeze fitting	For diameter > 130mm, dry ice or liquid nitrogen can be used
	<b>MAINTENANCE</b>	GAP-MET®/M is a maintenance-free sliding bearing, though oil or grease lubrication is possible.
	<p>* Other alloys are available!          ** Also available with cleaning grooves.          *** The above mentioned material properties are valid for optional operating conditions. Through changes of the application conditions e.g. higher sliding speed or strain, these values are subject to changes.</p>	

We produce all special designs at short notice! Special designs on customer's request are possible!

Self-lubricating sliding bearing • High-compressed with evenly applied solid lubricant  
Manufactured employing sintering technique • Maintenance-free



	<b>PROPERTIES</b>	High load capacity and stability, suitable for all slow movements and contaminated environments, no moisture absorption, good chemical resistance. Maintenance-free
<b>GAP-MET®/S</b>	<b>MATERIALS</b>	
STEEL BACKING	Support material	Steel (also as Bronze GAP-MET®/B or Stainless Steel GAP-MET®/N available)
<b>Cylindrical bushing</b>	Sliding layer* *	CuSn alloys; running-in: Graphite film (optional)
<b>GAZ/S</b>	<b>MATERIAL PROPERTIES * *</b>	
<b>Thrust washer</b>	Specific load capacity static	≤ 260 [ N/mm <sup>2</sup> ]
	Specific load capacity dynamic	≤ 80 [ N/mm <sup>2</sup> ]
<b>GAA/S</b>	Sliding speed	< 0.5 [ m/s ]
<b>Strips</b>	Friction value	0.10 – 0.18 [ μ ] dry
	Temperature strain	-150 – +280 [ °C ]
<b>GAS/S</b>	Max. p <sub>v</sub> - value	1.0 [ N/mm <sup>2</sup> x m/s ] dry
<b>BRONZE BACKING</b>	<b>TOLERANCE DETAILS</b>	
<b>Cylindrical bushing</b>	Housing Ø	H7
	Bushing Inner Ø after mounting	H8 / H9
	Shaft tolerance	d7 / e7
<b>GAZ/B</b>	<b>SHAFT MATERIAL</b>	Steel hardened > 180HB, surface roughness Ra ≤ 0.8 μm
<b>Thrust washer</b>	<b>MOUNTING ADVICE</b>	
<b>GAA/B</b>	Housing	Mounting chamfer, min. 1,5 mm x 15-45°
<b>Strips</b>	Shaft	Mounting chamfer, 5 mm x 15°, edges rounded
	Force fitting mandrel	Application of an adequate force fitting mandrel is advisable. Grease lubrication of the outer surface may be necessary when mounting.
<b>GAS/B</b>	Freeze fitting	For diameter > 130mm, dry ice or liquid nitrogen can be used
<b>STAINLESS STEEL BACKING</b>	<b>MAINTENANCE</b>	This GAP-MET® material is a maintenance-free sliding bearing. Though, oil or grease lubrication is possible.
<b>Cylindrical bushing</b>		
<b>GAZ/N</b>		
<b>Thrust washer</b>		
<b>GAA/N</b>		
<b>Strips</b>		
<b>GAS/N</b>		

\* On request further materials are available for higher demands, e.g. for higher temperature ranges.

\*\* Also with cleaning grooves available!

\*\*\* The above stated material properties are valid for optimal operating conditions. Through changes of the application conditions e.g. higher sliding speed or strain, these values are subject to change.

We produce all special designs at short notice! Special designs on customer's request are possible!

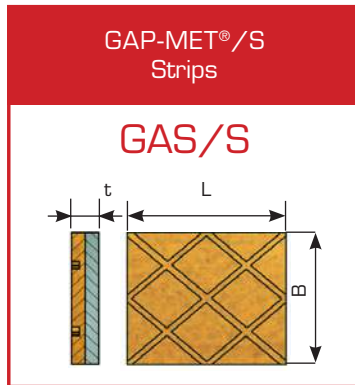
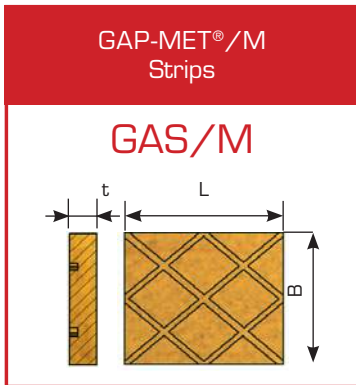
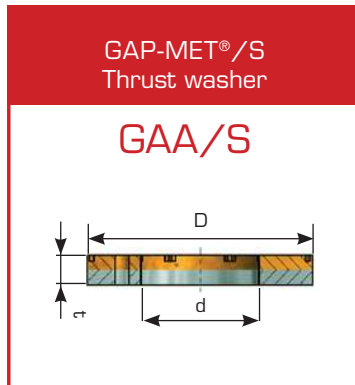
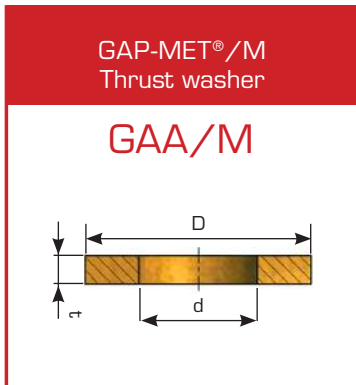
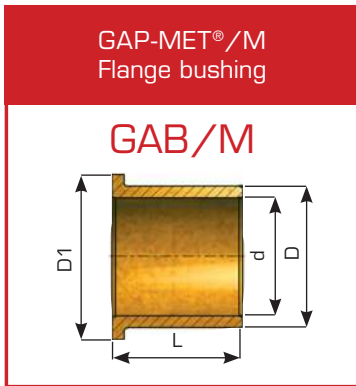
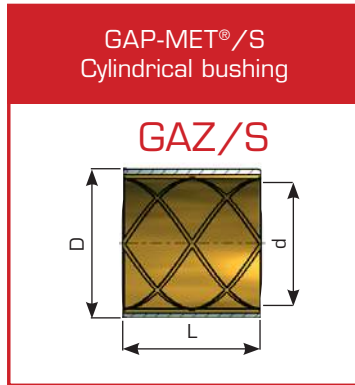
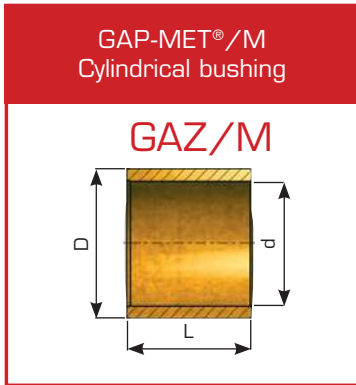

GA	Z/M	60	70	50
GA	Z/S	60	65	50
Type (GAP-MET®/M) Type (GAP-MET®/S)	Geometry (Cylindrical bushing)	Inner diameter GAP-MET®/M 60 mm (d) GAP-MET®/S 60 mm (d)	Outer diameter GAP-MET®/M 70 mm (D) GAP-MET®/S 65 mm (D)	Length GAP-MET®/M 50 mm (L) GAP-MET®/S 50 mm (L)

GA	B/M	60	70	50
Type (GAP-MET®/M)	Geometry (Flange bushing)	Inner diameter GAP-MET®/M 60 mm (d)	Outer diameter GAP-MET®/M 75 mm (D)	Length GAP-MET®/M 50 mm (L)

GA	A/M	30	60	10
GA	A/S	30	60	05
Type (GAP-MET®/M) Type (GAP-MET®/S)	Geometry (Thrust washer)	Inner diameter GAP-MET®/M 30 mm (d) GAP-MET®/S 30 mm (d)	Outer diameter GAP-MET®/M 60 mm (D) GAP-MET®/S 60 mm (D)	Thickness GAP-MET®/M 10 mm (t) GAP-MET®/S 5 mm (t)

GA	S/M	30	70	10
GA	S/S	30	70	05
Type (GAP-MET®/M) Type (GAP-MET®/S)	Geometry (Strip)	Width GAP-MET®/M 30 mm (B) GAP-MET®/S 30 mm (B)	Length GAP-MET®/M 70 mm (L) GAP-MET®/S 70 mm (L)	Thickness GAP-MET®/M 10 mm (t) GAP-MET®/S 5 mm (t)

All sizes and measurements can be produced to customer's specification.



# FER-MAS®



turned steel sliding bearing, heavy-maintenance

Hardened and grinded steel sliding bearing •  
Heavy maintenance



**FER-MAS®**

**Cylindrical bushing**

**FSZ**

### PROPERTIES

Suitable for highest operational demands, unsusceptible, high durability.  
Narrow tolerances possible.

### MATERIALS

20MnV6 hardened and grinded  
alternatively 100 Cr6 hardened and grinded

### MATERIAL PROPERTIES\*

Specific load capacity static	≤ 250 [ N/mm <sup>2</sup> ]
Specific load capacity dynamic	≤ 150 [ N/mm <sup>2</sup> ]
Sliding speed	< 0.6 [ m/s ]
Friction value	0.05 – 0.25 [ μ ]
Temperature strain	-100 – +250 [ °C ]
Max. p <sub>v</sub> - value	1.2 [ N/mm <sup>2</sup> x m/s ]
Hardness	58 – 62 [ HRC ]

### TOLERANCE DETAILS

Housing Ø	H7
Shaft tolerance	Specified by the customer.

### SHAFT MATERIAL

Hardened steel (C45 recommended)

### MOUNTING ADVICE

Housing	Mounting chamfer, min. 1.5 mm x 15-45°
Shaft	Mounting chamfer, 5 mm x 15°, edges rounded
Force fitting mandrel	Application of an adequate force fitting mandrel is advisable. Grease lubrication of the outer surface may be necessary when mounting.

### MAINTENANCE

Sufficient lubrication is necessary.

\* The above stated material properties are valid for optimal operating conditions. Through changes of the application conditions e.g. higher sliding speed or strain, these values are subject to changes.

Special sizes or special lubrication slots are available on demand!

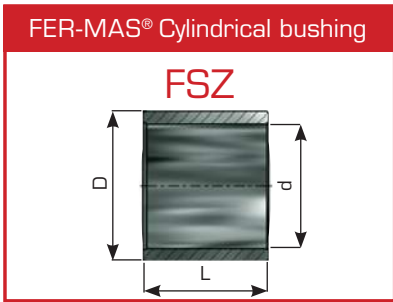

	L	20	25	30	35	40	45	50	55	60	65
d	D										
20	30	203020	203025	203030	203035	203040	203045	203050	203055	203060	203065
25	35			253530	253535	253540	253545	253550	253555	253560	253565
30	38			303830	303835	303840	303845	303850		303860	303865
30	40			304030	304035	304040	304045	304050	304055	304060	304065
35	45			354530	354535	354540	354545	354550	354555	354560	354565
40	50			405030	405035	405040	405045	405050	405055	405060	405065
45	55			455530	455535	455540	455545	455550	455555	455560	455565
50	60			506030	506035	506040	506045	506050	506055	506060	506065
55	65				556535	556540	556545	556550	556555	556560	556565
60	70				607035	607040	607045	607050	607055	607060	607065
65	75				657535	657540	657545	657550	657555	657560	657565
70	80				708035	708040	708045	708050	708055	708060	708065
75	85				758535	758540	758545	758550	758555	758560	758565
80	90					809040	809045	809050	809055	809060	809065
85	95					859540	859545	859550	859555	859560	
90	100					9010040	9010045	9010050	9010055	9010060	

	L	70	75	80	85	90	95	100
d	D							
20	30							
25	35	253570	253575	253580	253585	253590	253595	2535100
30	38	303870		303880				
30	40	304070	304075	304080	304085	304090	304095	3040100
35	45	354570	354575	354580	354585	354590	354595	3545100
40	50	405070	405075	405080	405085	405090	405095	4050100
45	55	455570	455575	455580	455585	455590	455595	4555100
50	60	506070	506075	506080	506085	506090	506095	5060100
55	65	556570	556575	556580		556590		
60	70	607070		607080		607090		6070100
65	75	657570		657580		657590		6575100
70	80	708070		708080		708090		7080100
75	85	758570		758580		758590		7585100
80	90	809070		809080		809090	809095	8090100
85	95	859570		859580		859590		8595100
90	100	9010070		9010080		9010090		90100100

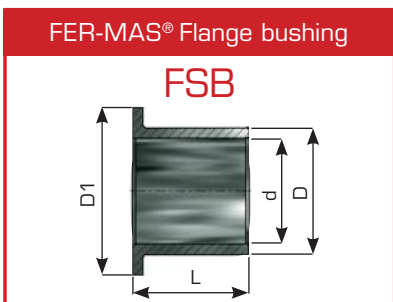

Flange bushings on customer's request.

# FER-MET®



wrapped steel bearing, inner and outer tension bushing,  
heavy-maintenance

Wrapped steel bearing • Inner and outer tension bushing •  
DIN 1498 / 1499



<p><b>FER-MET®</b></p> <p><b>Cylindrical bushing</b></p> <p><b>FMZ</b></p>	<p><b>PROPERTIES</b></p> <p>Extremely high load capacity, very wear-resistant, also suitable for heavy operational demands with impact load.</p>
	<p><b>MATERIALS</b></p> <p>Spring steel 55Si7, alternatively C67 or similar.</p>
	<p><b>GEOMETRY</b></p> <p>Form E Without chamfer at inner diameter</p> <p>Form F With chamfer at inner diameter</p> <p>Form G Straight slot</p> <p>Form P Arrowheaded slot</p> <p>Form S Slant slot</p>
	<p><b>TOLERANCE DETAILS</b></p> <p>Housing Ø H8</p> <p>Bushing Inner Ø after mounting According to DIN 1498/1499</p> <p>Shaft tolerance Specified by the customer.</p>
	<p><b>SHAFT MATERIAL</b></p> <p>Hardened steel (C45 recommended)</p> <p>Hardness +- 48 HRC</p>
<p><b>MOUNTING ADVICE</b></p> <p>Housing Mounting chamfer, min. 1.5 mm x 15-45°</p> <p>Shaft Mounting chamfer, 5 mm x 15°, edges rounded</p> <p>Force fitting mandrel Application of an adequate force fitting mandrel is advisable. Grease lubrication of the outer surface may be necessary when mounting.</p>	
<p><b>MAINTENANCE</b></p> <p>Sufficient lubrication is necessary.</p>	

FER-MET® is available only as cylindrical bushing! All special designs are available at short notice! Additional lubrication slots or lubrication drills on demand!

FER-MET® Cylindrical bushing

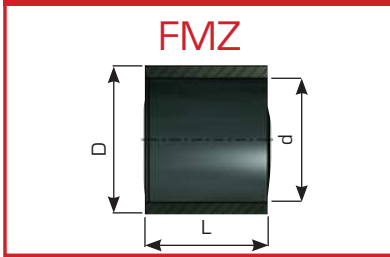

	L	10	12	14	16	18	20	22	25	28	36	40	45	50	60	70	80	100	
d	D																		
10	14	101410		101414			101420												
10	16	101610		101614			101620												
12	16	121610		121614			121620												
12	18	121810		121814			121820												
14	18	141810		141814			141820												
14	20	142010		142014			142020												
16	20		162012		162016		162020												
16	22		162212		162216		162220												
18	24			182414			182420			182428									
20	26			202614		202618				202628									
20	28			202814		202818				202828									
22	28			222814			222820			222828									
25	32			253214			253220			253228		253240							
25	35			253514			253520			253528		253540							
28	35			283514			283520			283528		283540							
30	38					303818			303825		303836			303850					
30	40					304018			304025		304036			304050					
32	40					324018			324025		324036			324050					
36	45					364518			364525		364536			364550					
40	50						405020					405040			405060		405080		
45	55							455522				455540			455560		455580		
50	60								506025					506050		506070		506100	
55	65								556525					556550			556580	5565100	
60	70								607025					607050		607070		6070100	
65	75								657525					657550		657570		6575100	
65	80								658025					658050		658070		6580100	
70	85								708525					708550		708570		7085100	
75	90								759025					759050		759070		7590100	

	L	40	45	50	60	70	80	100	110	120	140	160	200
80	95	809540			809560			8095100		8095120			
85	100	8510040			8510060			85100100		85100120			
90	105		9010545		9010560			90105100		90105120			
95	110		9511045		9511060			95110100		95110120			
100	115		10011545		10011560			100115100		100115120			
105	120			10512050			10512080	105120100			105120140		
110	125			11012550			11012580	110125100			110125140		
115	130			11513050			11513080	115130100			115130140		
120	135			12013550			12013580	120135100			120135140		
125	140			12514050			12514080	125140100			125140140		
130	145			13014550			13014580	130145100			130145140		
135	150				13515060		13515080		135150110			135150160	
140	155				14015560		14015580		140155110			140155160	
145	160				14516060		14516080		145160110			145160160	
150	165					15016570		150165100				150165160	150165200
155	175					15517570		155175100				155175160	155175200
160	180					16018070		160180100				160180160	160180200
170	190						17019080		170190110			170190160	170190200
175	195						17519580		175195110			175195160	175195200
180	200						18020080		180200110			180200160	180200200

# FER-MAN<sup>®</sup>246



low maintenance impact-resistance steel sliding bearing with very high surface hardness

# FER-MAN<sup>®</sup>259



Maintenance-free steel bushing, impact resistant, high breaking strength, able to absorb shock loadings

Impact-resistant steel sliding bearing with very high surface hardness •  
 Heat and corrosion resistant • Low maintenance



**FER-MAN®246**

**Cylindrical bushing**

**FNZ**

### PROPERTIES

Applicable for higher loads, heat and corrosion resistant, non-seizing, restricted abrasion-resistance, long-life bushing. Typical applications: e.g. replacement of bronze bearings which need to be lubricated intensively for dirt repellence. Very good for applications for minimum or initial lubricated bearing points with mechanical or/and thermal stress. Areas of applications: Crane bearings assemblies, front and rocker bearings, lifting devices, mining machinery.

### MATERIAL

Ferrous metal base, specially thermochemically treated, with lubrication patterns

### MATERIAL PROPERTIES \*

Specific load capacity static	≤ 400 [ N/mm <sup>2</sup> ]
Specific load capacity dynamic	≤ 100 [ N/mm <sup>2</sup> ]
Sliding speed	< 0.4 [ m/s ]
Friction value	0.12 – 0.16 [ μ ]
Temperature strain	< 400 [ C° ]
Surface hardness	550 – 650 [ HV ]
Core hardness	150 – 180 [ HB ]

### TOLERANCE DETAILS

Housing Ø	H7
Shaft tolerance	Specified by the customer (recommended f7)

### SHAFT MATERIAL

16 MnCr5 case-hardened or 42 CrMo4V inductive hardened

### MOUNTING ADVICE

Housing	Mounting chamfer, min. 1.5 mm x 15-45°
Shaft	Mounting chamfer, 5 mm x 15°, edges rounded
Force fitting mandrel	Application of an adequate force fitting mandrel is advisable. Grease lubrication of the outer surface may be necessary when mounting.

### MAINTENANCE

Initial and periodical lubrication is necessary.

\* The above stated material properties are valid for optimal operating conditions. Through changes of the application conditions e.g. higher sliding speed or strain, these values are subject to change.

We produce all special designs at short notice! All sizes will be produced according to customer's request. Special dimensions possible.



Maintenance-free steel bushing • Impact resistant •  
High breaking strength • Able to absorb shock loadings



<b>FER-MAN®259</b>	<b>PROPERTIES</b>		Excellent resistance to abrasion in heavily contaminated applications. Even under high temperatures, adhesion does not occur. The material has a very high load carrying capacity and shows a great resistance to shock loads and impacts. Typical applications are in steel mills for ladles trunnion and grabs, but also in dredging for clamshells buckets and excavators.
<b>Cylindrical bushing</b>	<b>MATERIAL</b>		Fe-C-Mn base material, treated with thermochemical process under vacuum conditions
<b>FNZ</b>	<b>MATERIAL PROPERTIES*</b>		
<b>Flange bushing</b>	Specific load capacity static		≤ 460 [ N/mm <sup>2</sup> ]
<b>FNB</b>	Specific load capacity dynamic		≤ 100 [ N/mm <sup>2</sup> ]
<b>Thrust washer</b>	Sliding speed		< 0.2 [ m/s ]
<b>FNA</b>	Friction value		0.2 – 0.28 (lubricated 0.12) [ μ ]
<b>Strips</b>	Temperature strain		< 200 (temporary up to 400) [ °C ]
<b>FNS</b>	Surface hardness		up to 950 [ HV ] (depending on application demands)
	Core hardness		150 – 180 [ HB ]
	<b>TOLERANCE DETAILS</b>		
	Housing Ø		H7
	Shaft tolerance		Specified by the customer (recommended h9)
	<b>SHAFT MATERIAL</b>		42 CrMo4V induction hardened, 54-57 HRC, 2-4 mm deep
	<b>MOUNTING ADVICE</b>		
	Housing		Mounting chamfer, min. 1.5 mm x 15-45°
	Shaft tolerance		Mounting chamfer, 5 mm x 15°, edges rounded
	Force fitting mandrel		Application of an adequate force fitting mandrel is advisable. Grease lubrication of the outer surface may be necessary when mounting.
	<b>MAINTENANCE</b>		FER-MAN®259 exhibits very good wear behavior without lubrication. However, at higher p <sub>v</sub> values (>0.2), lubrication is required.
	* The above stated material properties are valid for optimal operating conditions. Through changes of the application conditions e.g. higher sliding speed or strain, these values are subject to change.		

We produce all special designs at short notice! All sizes will be produced according to customer's request. Special dimensions possible.

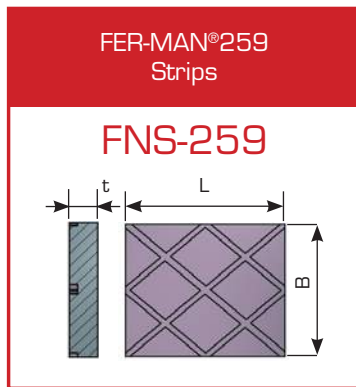
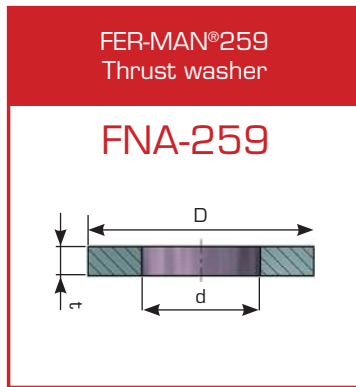
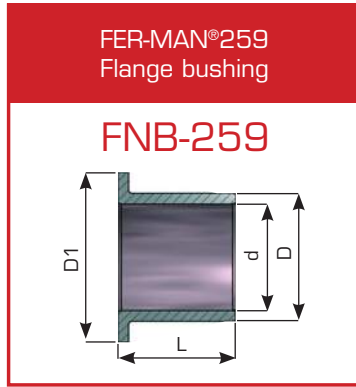
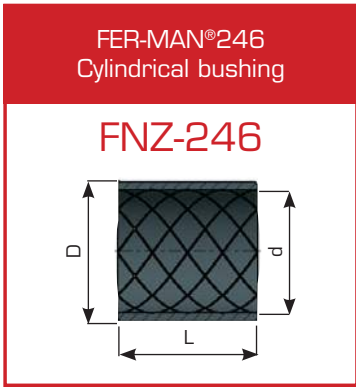

FN	Z-246	50	65	70
FN	Z-259	50	65	70
Type (FER-MAN®246) Type (FER-MAN®259)	Geometry (Cylindrical bushing)	Inner diameter FER-MAN®246 50 mm (d) FER-MAN®259 50 mm (d)	Outer diameter FER-MAN®246 65 mm (D) FER-MAN®259 65 mm (D)	Length FER-MAN®246 70 mm (L) FER-MAN®259 70 mm (L)

FN	B-259	50	65	70
Type (FER-MAN®259)	Geometry (Flange bushing)	Inner diameter FER-MAN®259 50 mm (d)	Outer diameter FER-MAN®259 65 mm (D)	Length FER-MAN®259 70 mm (L)

FN	A-259	30	60	05
Type (FER-MAN®259)	Geometry (Thrust washer)	Inner diameter FER-MAN®259 30 mm (d)	Outer diameter FER-MAN®259 60 mm (D)	Thickness FER-MAN®259 5 mm (t)

FN	S-259	30	70	10
Type (FER-MAN®259)	Geometry (Strip)	Width FER-MAN®259 30 mm (B)	Length FER-MAN®259 70 mm (L)	Thickness FER-MAN®259 10 mm (t)

# FLO-MAS®



rubber lined bearing, water lubricated

Rubber lined bearing • Water lubricated •  
Metallic and non-metallic bearing shell • Various bearing Lining

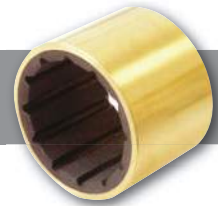

**FLO-MAS®**

**Cylindrical bushing**

**FLZ**

**PROPERTIES**

Suitable for water lubricated applications like pumps and propeller

**MATERIAL**

Bearing Shell	Non-ferrous	Alloy	BS 1400	ISO / DIN
		Aluminium Bronze	AB2	CuAl10Ni / 1714
Phosphor Bronze	PB1	CuSn10P / 1705		
Phosphor Bronze	PB2	CuSn12P		
Leaded Gun Metal	LG2	CuSn5ZnPb / 1705-RG5		
Leaded Gun Metal	SAE660	CuSn7ZnPb / 1705-RG7		
Naval Brass	BS2781 CZ112	CuZn38Zn1		
Bearing Shell	Ferrous	Austenitic - 316	316S18	W.Nr. - 1.4401
		Austenitic - 316L	316S14	W.Nr. - 1.4404
		Austenitic - 317	317S17	W.Nr. - 1.4449
		Martenitic 410	410S21	W.Nr. - 1.4024
		Duplex-wrought (Zeron 25)	UNS S31803	W.Nr. - 1.4462
		Super Duplex - wrought (Zeron 100)	UNS S32760	W.Nr. - 1.4501
		Super Duplex - cast	UNS J93380	W.Nr. - 1.4508
Non-metallic	COM-KU®/D (Fibre reinforced polyester)			
	Phenolic (paper based)			
Bearing Lining	Material	Major Properties		
	Polyurethane	Very tough and high strength material with excellent abrasion resistant properties. Ideal for dirty environment.		
	Nitrile Rubber (NBR)	Lower strength than Polyurethane, yet resistant against oil, low water swell, very good heat resistant.		
	On request special produced elastomers like Butyl, Ethylene Propylene (EPDM), Fluoroelastomers (Viton)	For special demand of applications, i.e. high temperature, low temperature, chemical resistance, etc.		

**MATERIAL PROPERTIES**

	Polyurethane	Nitrile Rubber (NBR)
Specific load capacity dynamic	≤ 4 [ N/mm² ]	≤ 4 [ N/mm² ]
Sliding speed	≤ 35 [ m/s ]	≤ 35 [ m/s ]
Hardness (IRHD)	90	70
Tensile Strength (MPa)	31	11
Modulus @ 100% (MPa)	7.6	3.7
Elongation at Break (%)	450	250
Tear Strength (MPa)	42	22
Compression Set (22hrs @ 70 °C)	27	20

**TOLERANCE DETAILS**

Housing Ø	Specified by the customer
Bushing Inner Ø after mounting	Specified by the customer
Shaft tolerance	Specified by the customer

**SHAFT MATERIAL**

Various stainless steel grades depending on application requirements

**MAINTENANCE**

FLO-MAS® needs water lubrication!

We produce all special designs at short notice! We are able to produce bearings with an integral cast flange, as required to customer specifications. Additional features such as water inlet holes, lips, internal and external steps and milled slots are possible.

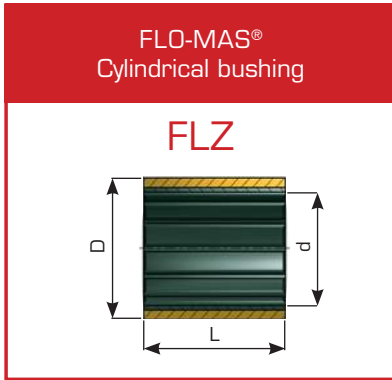

FL	Z	50	70	50
Type (FLO-MAS®)	Geometry (Cylindrical bushing)	Inner diameter 50 mm (d)	Outer diameter 70 mm (D)	Length 50 mm (L)

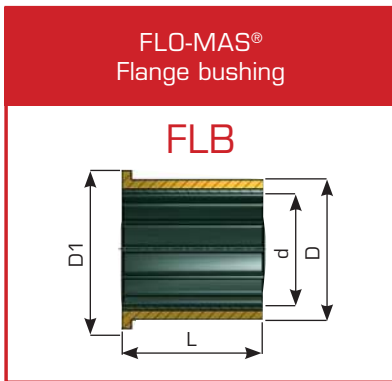

FL	B	50	70	50
Type (FLO-MAS®)	Geometry (Flange bushing)	Inner diameter 50 mm (d)	Outer diameter 70 mm (D)	Length 50 mm (L)

All sizes and measurements can be produced to customer's specification.

# TEF-MET®



wrapped composite dry sliding bearing, steel/PTFE, maintenance-free

# TEF-MET®/B



wrapped composite sliding bearing, bronze/PTFE, maintenance-free

Wrapped composite bearing with PTFE sliding layer •  
Maintenance-free • DIN 1494 / ISO 3547



	<b>PROPERTIES</b>	Excellent sliding and wear behaviour, for all types of movement, high load capacity.	
<b>TEF-MET®</b>	<b>MATERIALS</b>	TEF-MET®	TEF-MET®/B
<b>Cylindrical bushing</b>	Support material	Steel tin-plated	Bronze
<b>TFZ</b>	Intermediate layer	Sintered bronze	Sintered bronze
	Sliding layer	PTFE	PTFE
<b>Flange bushing</b>	<b>MATERIAL PROPERTIES</b>		
<b>TFB</b>	Specific load capacity static	≤ 250 [ N/mm <sup>2</sup> ]	
	Specific load capacity dynamic	≤ 140 [ N/mm <sup>2</sup> ] at low sliding speeds	
<b>Thrust washer</b>	Sliding speed	≤ 2.5 [ m/s ]	
	Friction value	0,03 – 0,25 [ μ ]	
<b>TFA</b>	Temperature strain	-200 – +280 [ °C ]	
	Max. p <sub>v</sub> - value	1.8 [ N/mm <sup>2</sup> x m/s ] for a short time 3.6	
<b>Strips</b>	<b>TOLERANCE DETAILS</b>		
<b>TFS</b>	Housing Ø	H7	
	Bushing Inner Ø after mounting	H9	
<b>TEF-MET®/B</b>	Shaft tolerance	f7 or h8	
<b>Cylindrical bushing</b>	<b>SHAFT MATERIAL</b>	Steel, hardened or untempered, surface roughness R <sub>a</sub> < 0.8 μm	
<b>TFZ/B</b>	<b>MOUNTING ADVICE</b>		
	Housing	Mounting chamfer, min. 1.5 mm x 15-45°	
<b>Flange bushing</b>	Shaft	Mounting chamfer, 5 mm x 15°, edges rounded	
	Force fitting mandrel	Application of an adequate force fitting mandrel is advisable. Grease lubrication of the outer surface may be necessary when mounting.	
<b>TFB/B</b>	Glueing	Adhesive should not contact the sliding surface.	
<b>Thrust washer</b>	<b>MAINTENANCE</b>	TEF-MET® is a dry sliding bearing with a PTFE sliding layer. Lubrication is therefore not necessary, but basically possible!	
<b>TFA/B</b>			
<b>Strips</b>			
<b>TFS/B</b>			

We produce all special designs at short notice! Cylindrical and flange bushings, thrust washer, strips are standard fabrication. Punchings and moldings are produced on customer's requirement.

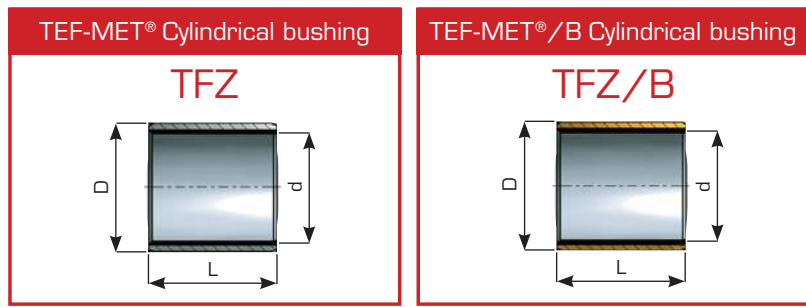

	L	03	04	06	08	10	12	15	20	25	30	35	40	50
d	D													
03	4.5	0303	0304											
04	5.5		0404	0406										
06	08		0604	0606	0608	0610								
07	09			0706	0708	0710		0715						
08	10			0806	0808	0810	0812	0815						
10	12			1006	1008	1010	1012	1015	1020					
12	14			1206	1208	1210	1212	1215	1220	1225				
13	15					1310	1312	1315						
14	16					1410	1412	1415	1420	1425				
15	17				1508	1510	1512	1515	1520	1525				
16	18				1608	1610	1612	1615	1620	1625				
17	19				1708	1710	1712	1715	1720	1725				
18	20				1808	1810	1812	1815	1820	1825	1830			
20	22					2010A	2012A	2015A	2020A	2025A	2030A	2035A	2040A	
20	23				2008B	2010B	2012B	2015B	2020B	2025B	2030B	2035B	2040B	
22	25				2208	2210	2212	2215	2220	2225	2230	2235	2240	2250
24	27					2410A	2412A	2415A	2420A	2425A	2430A	2435A	2440A	2450A
24	28					2410B	2412B	2415B	2420B	2425B	2430B	2435B	2440B	2450B
25	28					2510	2512	2515	2520	2525	2530	2535	2540	2550
26	30					2610	2612	2615	2620	2625	2630	2635	2640	2650
28	32					2810	2812	2815	2820	2825	2830	2835	2840	2850
30	34					3010	3012	3015	3020	3025	3030	3035	3040	3050
32	36					3210	3212	3215	3220	3225	3230		3240	3250
35	39					3510	3512	3515	3520	3525	3530	3535	3540	3550

	L	12	15	20	25	30	35	40	50	60	70	80	90	100
d	D													
38	42	3812	3815	3820	3825	3830	3835	3840	3850	3860				
40	44	4012	4015	4020	4025	4030	4035	4040	4050	4060				
42	46	4212	4215	4220	4225	4230	4235	4240	4250	4260				
45	50		4515	4520	4525	4530	4535	4540	4550	4560				
50	55		5015	5020	5025	5030	5035	5040	5050	5060	5070			
55	60		5515	5520	5525	5530	5535	5540	5550	5560	5570			
60	65		6015	6020	6025	6030	6035	6040	6050	6060	6070	6080	6090	
65	70		6515	6520		6530		6540	6550	6560	6570	6580	6590	
70	75			7020		7030		7040	7050	7060	7070	7080	7090	
75	80			7520		7530		7540	7550	7560	7570	7580	7590	
80	85					8030		8040	8050	8060	8070	8080	8090	80100
85	90					8530		8540	8550	8560	8570	8580	8590	85100
90	95					9030		9040	9050	9060	9070	9080	9090	90100
95	100					9530		9540	9550	9560	9570	9580	9590	95100
100	105					10030		10040	10050	10060	10070	10080	10090	100100



	L	50	60	70	80	90	100	110	115	120	130	140	150
d	D												
105	110	10550	10560	10570	10580	10590	105100		105115				
110	115	11050	11060	11070	11080	11090	110100		110115				
115	120	11550	11560	11570	11580	11590	115100		115115				
120	125	12050	12060	12070	12080	12090	120100			120120			
125	130	12550	12560	12570	12580	12590	125100		125115				
130	135		13060	13070	13080	13090	130100			130120			
135	140		13560	13570	13580	13590	135100			135120			
140	145		14060	14070	14080	14090	140100						
150	155		15060	15070	15080	15090	150100						
160	165		16060	16070	16080	16090	160100	160110		160120	160130	160140	160150
170	175		17060	17070	17080	17090	170100	170110		170120	170130	170140	170150
180	185		18060	18070	18080	18090	180100	180110		180120	180130	180140	180150
200	205		20060	20070	20080	20090	200100	200110		200120	200130	200140	200150
220	225		22060	22070	22080	22090	220100	220110		220120	220130	220140	220150
250	255		25060	25070	25080	25090	250100	250110		250120	250130	250140	250150
300	305		30060	30070	30080	30090	300100	300110		300120	300130	300140	300150

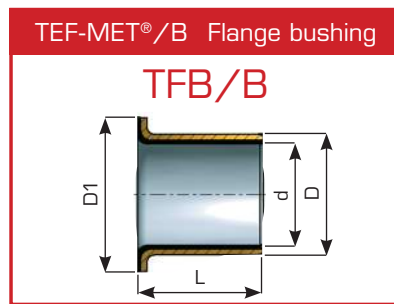
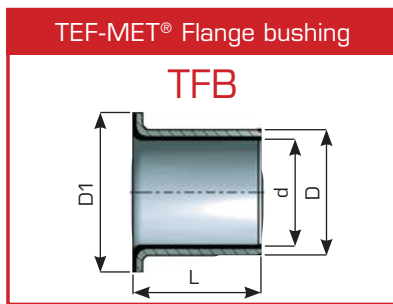

d	D	D1	L	Flange thickness	04	05	05,5	06	07	07,5	08	09	09,5	10
03	4.5	7	0.75		0304									
04	5.5	9	0.75		0404									0410
05	07	10	1			0505		0506						
06	08	12	1		0604			0606	0607		0608			0610
08	10	15	1				0805,5			0807,5			0809,5	0810
10	12	18	1						1007			1009		1010
12	14	20	1					1206	1207			1209		1210
14	16	22	1											1410
15	17	23	1									1509		1510

d	D	D1	L	Flange thickness	11	11.5	12	15	16	16.5	17	20	21.5	22
10	12	18	1		1011		1012	1015			1017			
12	14	20	1				1212	1215			1217	1220		
13	15	21	1					1315				1320		
14	16	22	1				1412	1415			1417	1420		
15	17	23	1		1511		1512	1515			1517	1520		
16	18	24	1				1612	1615			1617			1622
18	20	26	1				1812	1815			1817			1822
20	23	30	1.5			2011,5		2015		2016.5		2020	2021.5	
22	25	33	1.5			2211.5				2216.5			2221.5	
25	28	35	1.5			2511.5	2512			2516.5			2521.5	
30	34	42	2						3016			3020		3022
32	36	46	2											3222
35	39	47	2						3516			3520		3522
40	44	53	2									4020		
45	50	58	2.5						4516					4522
50	55	65	2.5						5016			5020		5022

	L			25	26	26.5	30	40	50	60	70	80	100
d	D	D1	Flange thickness										
20	23	30	1.5	2025		2026.5							
22	25	33	1.5			2226.5							
25	28	35	1.5			2526.5							
30	34	42	2		3026		3030	3040					
32	36	46	2				3230						
35	39	47	2		3526		3530	3540	3550				
40	44	53	2		4026		4030	4040					
45	50	58	2.5		4526		4530	4540					
50	55	65	2.5	5025	5026		5030	5040	5050	5060			
55	60	70	2.5					5540					
60	65	75	2.5				6030	6040	6050	6060			
70	75	85	2.5				7030	7040	7050		7070		
75	80	90	2.5							7560		7580	
80	85	95	2.5					8040	8050	8060		8080	80100
85	90	100	2.5										85100
90	95	110	2.5					9040		9060		9090	90100
100	105	120	2.5							10060	10070		100100
110	115	130	2.5							11060			
120	125	150	2.5							12060	12070		120100
130	135	155	2.5										130100
140	145	165	2.5							14060		14080	
160	165	190	2.5									16080	160100
220	225	235	2.5										220100
250	255	290	2.5										250100

TEF-MET® Thrust washer

TFA

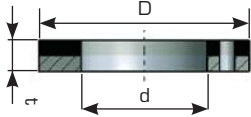

TEF-MET®/B Thrust washer

TFA/B

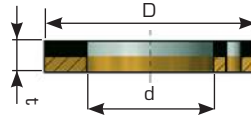

Art. Nr.	d	D	t
TFA 10/1	10	20	1.5
TFA 12/1	12	24	1.5
TFA 14/1	14	26	1.5
TFA 16/1	16	30	1.5
TFA 18/1	18	32	1.5
TFA 20/1	20	36	1.5
TFA 22/1	22	38	1.5
TFA 24/1	24	42	1.5
TFA 26/1	26	44	1.5
TFA 28/1	28	48	1.5
TFA 32/1	32	54	1.5
TFA 38/1	38	62	1.5
TFA 42/1	42	66	1.5
TFA 48/2	48	74	2.0
TFA 52/2	52	78	2.0
TFA 62/2	62	90	2.0

Art. Nr.	d	D	t
TFA/B 10/1	10	20	1.5
TFA/B 12/1	12	24	1.5
TFA/B 14/1	14	26	1.5
TFA/B 16/1	16	30	1.5
TFA/B 18/1	18	32	1.5
TFA/B 20/1	20	36	1.5
TFA/B 22/1	22	38	1.5
TFA/B 24/1	24	42	1.5
TFA/B 26/1	26	44	1.5
TFA/B 28/1	28	48	1.5
TFA/B 32/1	32	54	1.5
TFA/B 38/1	38	62	1.5
TFA/B 42/1	42	66	1.5
TFA/B 48/2	48	74	2
TFA/B 52/2	52	78	2
TFA/B 62/2	62	90	2

TEF-MET® Strips

TFS

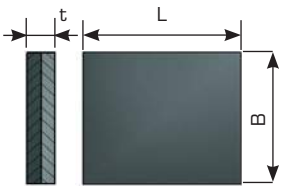

TEF-MET®/B Strips

TFS/B

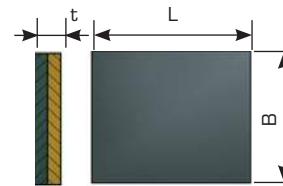

Art. Nr.	B	L	t
TFS 10240	245	500	1.0
TFS 15240	245	500	1.5
TFS 20240	245	500	2.0
TFS 25240	245	500	2.5
TFS 30240	245	500	3.0

Art. Nr.	B	L	t
TFS/B 10240	245	500	1.0
TFS/B 15240	245	500	1.5
TFS/B 20240	245	500	2.0
TFS/B 25240	245	500	2.5
TFS/B 30240	245	500	3.0

# NOX-MET®



wrapped composite sliding bearing, stainless steel/PTFE, maintenance-free

Wrapped composite sliding bearing, stainless steel / PTFE coated •  
Maintenance-free • DIN 1494 / ISO 3547



<b>NOX-MET®</b>  <b>Cylindrical bushing</b>  <b>NXZ</b>  <b>Flange bushing</b>  <b>NXB</b>  <b>Thrust washer</b>  <b>NXA</b>  <b>Strips</b>  <b>NXS</b>	<h2 style="color: #c00000;">PROPERTIES</h2>	<p>Excellent sliding and wear behaviour, for all types of movement, high load capacity, all-round adaptable.</p>
	<h2 style="color: #c00000;">MATERIALS</h2>	<p>Support material SS 304 (1.4301) / SS 316 (1.4401)                  Intermediate layer Sintered bronze (only for SS 304)                  Sliding layer PTFE</p>
	<h2 style="color: #c00000;">MATERIAL PROPERTIES</h2>	<p>Specific load capacity static <math>\leq 250</math> [ N/mm<sup>2</sup> ]                  Specific load capacity dynamic <math>\leq 140</math> [ N/mm<sup>2</sup> ] at low sliding speeds                  Sliding speed <math>\leq 2.0</math> [ m/s ]                  Friction value 0.02 – 0.20 [ <math>\mu</math> ]                  Temperature strain -200 – +280 [ °C ]                  Max. <math>p_v</math> - value 1.8 [ N/mm<sup>2</sup> x m/s ] for a short time 3.6</p>
	<h2 style="color: #c00000;">TOLERANCE DETAILS</h2>	<p>Housing <math>\emptyset</math> H7                  Bushing Inner <math>\emptyset</math> after mounting H9                  Shaft tolerance f7 or h8</p>
	<h2 style="color: #c00000;">SHAFT MATERIAL</h2>	<p>Steel, hardened or untempered, wsurface roughness <math>R_a &lt; 4 \mu\text{m}</math></p>
	<h2 style="color: #c00000;">MOUNTING ADVICE</h2>	<p>Housing Mounting chamfer, min. 1.5 mm x 15-45°                  Shaft Mounting chamfer, 5 mm x 15°, edges rounded                  Force fitting mandrel Application of an adequate force fitting mandrel is advisable.                  Grease lubrication of the outer surface may be necessary when mounting.</p>
	<h2 style="color: #c00000;">MAINTENANCE</h2>	<p>NOX-MET® is a dry sliding bearing with PTFE sliding layer. Lubrication is therefore not necessary, but basically possible!</p>

We produce all special designs at short notice! Cylindrical and flange bushings, thrust washer, strips are standard fabrication. Punchings and moldings are produced on customer's requirement.

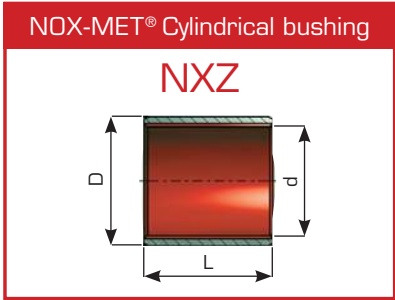

	L	03	04	06	08	10	12	15	20	25	30	35	40	50
d	D													
03	4.5	0303	0304											
04	5.5	403	0404	0406	408									
06	08		0604	0606	0608	0610								
07	09			0706	0708	0710		0715						
08	10			0806	0808	0810	0812	0815	820					
10	12			1006	1008	1010	1012	1015	1020					
12	14			1206	1208	1210	1212	1215	1220	1225				
13	15					1310	1312	1315	1320					
14	16					1410	1412	1415	1420	1425				
15	17				1508	1510	1512	1515	1520	1525				
16	18				1608	1610	1612	1615	1620	1625				
17	19					1710	1712	1715	1720	1725				
18	20				1808	1810	1812	1815	1820	1825	1830			
20	22					2010A	2012A	2015A	2020A	2025A	2030A		2040A	
20	23					2010B	2012B	2015B	2020B	2025B	2030B		2040B	
22	25					2210	2212	2215	2220	2225	2230			2250
24	27					2410A	2412A	2415A	2420A	2425A	2430A			2450A
24	28					2410B	2412B	2415B	2420B	2425B	2430B		2440B	2450B
25	28					2510	2512	2515	2520	2525	2530	2535	2540	2550
26	30					2610	2612	2615	2620	2625	2630	2635	2640	2650
28	32					2810	2812	2815	2820	2825	2830		2840	2850
30	34					3010	3012	3015	3020	3025	3030	3035	3040	3050
32	36					3210	3212	3215	3220	3225	3230		3240	3250
35	39					3510	3512	3515	3520	3525	3530	3535	3540	3550

	L	15	20	25	30	35	40	45	50	55	60	70	80	90
d	D													
38	42	3815	3820	3825	3830	3835	3840		3850	3855	3860			
40	44	4015	4020	4025	4030	4035	4040	4045	4050	4055	4060			
42	46	4215	4220	4225	4230	4235	4240		4250		4260			
45	50	4515	4520	4525	4530	4535	4540	4545	4550		4560			
50	55	5015	5020	5025	5030	5035	5040	5045	5050	5055	5060	5070	5080	
55	60	5515	5520	5525	5530	5535	5540	5545	5550	5555	5560	5570		
60	65	6015	6020	6025	6030	6035	6040	6045	6050	6055	6060	6070	6080	6090
65	70	6515	6520	6525	6530	6540	6545	6550	6555	6560	6570	6580	6590	6590
70	75	7015	7020	7025	7030	7035	7040	7045	7050		7060	7070	7080	7090
75	80				7530		7540	7545	7550		7560	7570	7580	7590
80	85	8015	8020	8025	8030	8035	8040	8045	8050		8060	8070	8080	8090
85	90		8520		8530		8540		8550		8560	8570	8580	8590
90	95	9015	9020		9030		9040		9050	9055	9060	9070	9080	9090
95	100			9525	9530		9540	9545	9550		9560	9570	9580	9590
100	105	10015		10025	10030		10040		10050	10055	10060	10070	10080	10090

	L	50	60	70	80	90	100	110	115	120	130	140	150
d	D												
100	105						100100	100110	100115				
105	110	10550	10560	10570	10580	10590	105100		105115				
110	115	11050	11060	11070	11080	11090	110100	110110	110115	110120			
115	120	11550	11560	11570			115100		115115	115120			
120	125	12050	12060	12070	12080	12090	120100			120120			
125	130	12550	12560	12570	12580		125100						
130	135		13060	13070	13080	13090	130100						
135	140		13560	13570	13580	13590	135100						
140	145		14060	14070	14080	14090	140100						
150	155		15060	15070	15080	15090	150100						
160	165		16060	16070	16080	16090	160100	160110		160120	160130	160140	160150
170	175		17060	17070	17080	17090	170100	170110		170120	170130	170140	170150
180	185		18060	18070	18080	18090	180100	180110		180120	180130	180140	180150
200	205		20060	20070	20080	20090	200100	200110		200120	200130	200140	200150
220	225		22060	22070	22080	22090	220100	220110		220120	220130	220140	220150
250	255		25060	25070	25080	25090	250100	250110		250120	250130	250140	250150
300	305		30060	30070	30080	30090	300100	300110		300120	300130	300140	300150

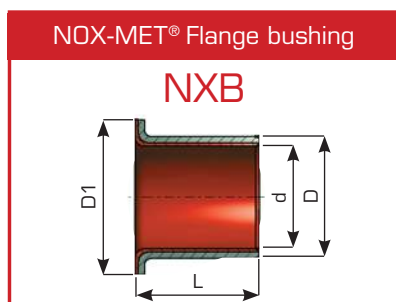

d	D	D1	L	Flange thickness	04	05	05,5	06	07	07,5	08	09	09,5	10
03	4.5	7	0.75	0.75	0304									
04	5.5	9	0.75	0.75	0404									0410
05	07	10	1	1		0505		0506						
06	08	12	1	1	0604			0606	0607		0608			0610
08	10	15	1	1			0805,5			0807,5			0809,5	0810
10	12	18	1	1					1007			1009		1010
12	14	20	1	1				1206	1207			1209		1210
14	16	22	1	1										1410
15	17	23	1	1								1509		1510

d	D	D1	L	Flange thickness	11	11.5	12	15	16	16.5	17	20	21.5	22
10	12	18	1	1	1011			1012	1015			1017		
12	14	20	1	1				1212	1215			1217	1220	
13	15	21	1	1					1315				1320	
14	16	22	1	1				1412	1415			1417	1420	
15	17	23	1	1	1511			1512	1515			1517	1520	
16	18	24	1	1				1612	1615			1617		1622
18	20	26	1	1				1812	1815			1817		1822
20	23	30	1.5	1.5			2011,5		2015		2016,5		2020	2021,5
22	25	33	1.5	1.5			2211,5				2216,5			2221,5
25	28	35	1.5	1.5			2511,5	2512			2516,5			2521,5
30	34	42	2	2					3016			3020		3022
32	36	46	2	2										3222
35	39	47	2	2					3516			3520		3522
40	44	53	2	2								4020		
45	50	58	2.5	2.5					4516					4522
50	55	65	2.5	2.5					5016			5020		5022

d	D	D1	L	Flange thickness	25	26	26,5	30	40	50	60	70	80	100
20	23	30	1,5	1,5	2025			2026,5						
22	25	33	1,5	1,5				2226,5						
25	28	35	1,5	1,5				2526,5						
30	34	42	2	2			3026	3030	3040					
32	36	46	2	2				3230						
35	39	47	2	2			3526	3530	3540	3550				
40	44	53	2	2			4026	4030	4040					
45	50	58	2,5	2,5			4526	4530	4540					
50	55	65	2,5	2,5	5025	5026		5030	5040	5050	5060			
55	60	70	2,5	2,5					5540					
60	65	75	2,5	2,5				6030	6040	6050	6060			
70	75	85	2,5	2,5				7030	7040	7050		7070		
75	80	90	2,5	2,5							7560		7580	
80	85	95	2,5	2,5					8040	8050	8060		8080	80100
85	90	100	2,5	2,5										85100
90	95	110	2,5	2,5					9040		9060		9090	90100



	L												
	25 26 26,5 30 40 50 60 70 80 100												
d	D	D1	Flange thickness										
100	105	120	2,5							10060	10070		100100
110	115	130	2,5							11060			
120	125	150	2,5							12060	12070		120100
130	135	155	2,5										130100
140	145	165	2,5							14060		14080	
160	165	190	2,5									16080	160100
220	225	235	2,5										220100
250	255	290	2,5										250100

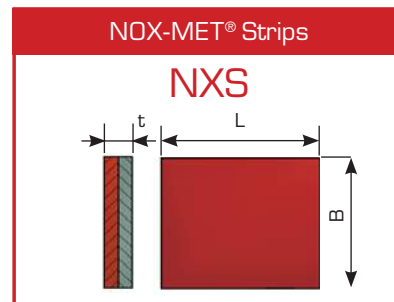
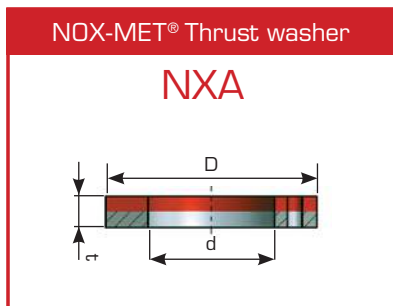

Art. Nr.	d	D	t
NXA 10/1	10	20	1.5
NXA 12/1	12	24	1.5
NXA 14/1	14	26	1.5
NXA 16/1	16	30	1.5
NXA 18/1	18	32	1.5
NXA 20/1	20	36	1.5
NXA 22/1	22	38	1.5
NXA 24/1	24	42	1.5
NXA 26/1	26	44	1.5
NXA 28/1	28	48	1.5
NXA 32/1	32	54	1.5
NXA 38/1	38	62	1.5
NXA 42/1	42	66	1.5
NXA 48/2	48	74	2
NXA 52/2	52	78	2
NXA 62/2	62	90	2

Art. Nr.	B	L	t
NXS 10240	245	500	1,0
NXS 15240	245	500	1.5
NXS 20240	245	500	2.0
NXS 25240	245	500	2.5
NXS 30240	245	500	3.0

# POM-MET®



wrapped composite sliding bearing, steel/acetal resin (POM),  
lubrication pockets, low-maintenance

Wrapped composite sliding bearing, steel / POM, with lubrication pockets •  
Low-maintenance • DIN 1494 / ISO 3547

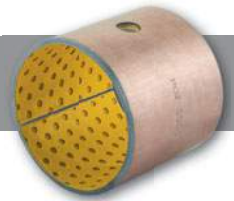

<b>POM-MET®</b>  <b>Cylindrical bushing</b>  <b>POZ</b>  <b>Thrust washer</b>  <b>POA</b>  <b>Strips</b>  <b>POS</b>	<b>PROPERTIES</b>	Suitable for grease or oil lubrication and all kinds of movements, good load capacity, robust and insensible to dirt.
	<b>MATERIALS</b>	
	Support material	Steel copper plated / tinplated
	Intermediate layer	Sintered bronze
	Sliding layer	Acetal resin / POM
	<b>MATERIAL PROPERTIES</b>	
	Specific load capacity static	≤ 250 [ N/mm <sup>2</sup> ]
	Specific load capacity dynamic	≤ 140 [ N/mm <sup>2</sup> ] at low sliding speeds
	Sliding speed	≤ 2.5 [ m/s ]
	Friction value	0.04 – 0.12 [ μ ] depending on lubrication
Temperature strain	-40 – +130 [ °C ] for a short time up to +130 °C	
Max. p <sub>v</sub> - value	2.8 [ N/mm <sup>2</sup> x m/s ]	
<b>TOLERANCE DETAILS</b>		
Housing Ø	H7	
Bushing Inner Ø after mounting	D9	
Shaft tolerance	h8	
<b>SHAFT MATERIAL</b>		
	Steel, hardened or untempered, surface roughness R <sub>a</sub> < 4 μm	
<b>MOUNTING ADVICE</b>		
Housing	Mounting chamfer, min. 1.5 mm x 15-45°	
Shaft	Mounting chamfer, 5 mm x 15°, edges rounded	
Force fitting mandrel	Application of an adequate force fitting mandrel is advisable. Grease lubrication of the outer surface may be necessary when mounting.	
Glueing	Adhesive should not contact the sliding surface.	
<b>MAINTENANCE</b>		
	POM-MET® is a low-maintenance composite bearing with a POM sliding layer. Primary lubrication is necessary. Oil or grease lubrication is possible. Because of lubrication pockets lubrication intervals are reduced to a minimum!	

We produce all special designs at short notice! Additional lubrication slots or lubrication drills on demand! Cylindrical bushings, thrust washer and strips are standard fabrication.

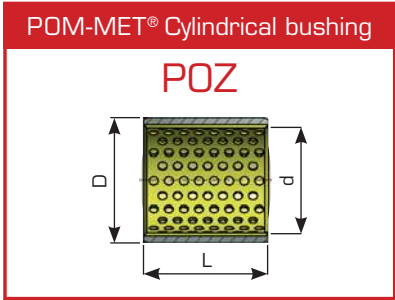

	L	05	06	08	10	12	15	20	25	30	35	40	50	60
d	D													
05	7	0505												
06	08		0606	0608	0610									
07	09				0710									
08	10	0805	0806	0808	0810	0812								
10	12		1006	1008	1010	1012	1015	1020						
12	14			1208	1210	1212	1215	1220	1225					
13	15				1310									
14	16				1410	1412	1415	1420	1425					
15	17				1510	1512	1515	1520	1525					
16	18			1608	1610	1612	1615	1620	1625					
17	19						1715	1720						
18	20				1810	1812	1815	1820	1825					
20	22				2010A		2015A	2020A						
20	23				2010B	2012B	2015B	2020B	2025B	2030B	2040B			
22	25						2215	2220	2225	2230	2240			
24	27					2412	2415	2420	2425	2430	2440	2450		
25	28				2510	2512	2515	2520	2525	2530	2540	2550		
26	30									2630	2640	2650		
28	31								2825A	2830A				
28	32						2815B	2820B	2825	2830	2840			
30	34				3010	3012	3015	3020	3025	3030	3040	3050		
32	36							3220	3225	3230	3240	3250		
35	39						3515	3520	3525	3530	3540	3550		
38	42						3815	3820	3825	3830	3835	3840	3850	3860
40	44				4010			4020	4025	4030	4035	4040	4050	4060
45	50							4520		4530	4535	4540	4550	4560

	L	10	15	20	25	30	35	40	50	60	70	80	90	100
d	D													
50	55		5015	5020	5025	5030	5035	5040	5050	5060	5070			
55	60	5510	5515	5520	5525	5530	5535	5540	5550	5560	5570			
60	65	6010	6015	6020	6025	6030	6035	6040	6050	6060	6070	6080	6090	
65	70		6515	6520	6525	6530	6535	6540	6550	6560	6570	6580		
70	75			7020	7025	7030	7035	7040	7050	7060	7070	7080	7090	
75	80			7520		7530		7540	7550	7560	7570	7580		
80	85					8030		8040	8050	8060	8070	8080		80100
85	90			8520		8530		8540	8550	8560	8570	8580	8590	85100
90	95					9030		9040	9050	9060	9070	9080	9090	90100
95	100					9530		9540	9550	9560	9570	9580	9590	95100
100	105					10030		10040	10050	10060	10070	10080	10090	100100
105	110							10540	10550	10560	10570	10580	10590	105100
110	115							11040	11050	11060	11070	11080	11090	110100
120	125			12020				12040	12050	12060	12070	12080	12090	120100

	L	50	60	70	80	90	100	110	115	120	130	140	150
d	D												
105	110							105110	105115				
110	115							110110	110115				
115	120	11550	11560	11570	11580	11590	115100	115110	115115				
120	125							120110	120115	120120		120140	
125	130	12550	12560	12070	12580	12590	125100	125110	125115	125120			
130	135	13050	13060	13070	13080	13090	130100	130110		130120		130140	
135	140	13550	13560	13570	13580	13590	135100	135110		135120			
140	145	14050	14060	14070	14080	14090	140100	140110		140120			
150	155	15050	15060	15070	15080	15090	150100	150110		150120			150150
160	165	16050	16060	16070	16080	16090	160100	160110		160120	160130	160140	160150
170	175	17050	17060	17070	17080	17090	170100	170110		170120	170130	170140	170150
180	185	18050	18060	18070	18080	18090	180100	180110		180120	180130	180140	180150
200	205	20050	20060	20070	20080	20090	200100	200110		200120	200130	200140	200150
220	225	22050	22060	22070	22080	22090	220100	220110		220120	220130	220140	220150
250	255		25060	25070	25080	25090	250100	250110		250120	250130	250140	250150
300	305		30060	30070	30080	30090	300100	300110		300120	300130	300140	300150

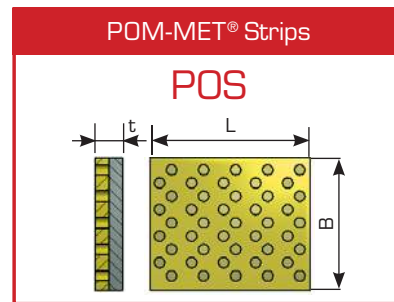
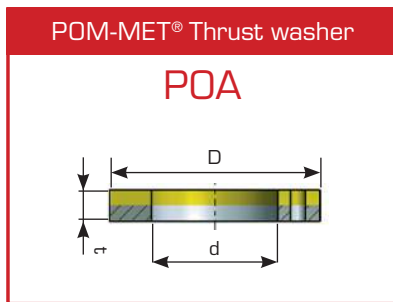

Art. Nr.	d	D	t
POA 10/1	10	20	1.5
POA 12/1	12	24	1.5
POA 14/1	14	26	1.5
POA 16/1	16	30	1.5
POA 18/1	18	32	1.5
POA 20/1	20	36	1.5
POA 22/1	22	38	1.5
POA 24/1	24	42	1.5
POA 26/1	26	44	1.5
POA 28/1	28	48	1.5
POA 32/1	32	54	1.5
POA 38/1	38	62	1.5
POA 42/1	42	66	1.5
POA 48/2	48	74	2
POA 52/2	52	78	2
POA 62/2	62	90	2

Art. Nr.	B	L	t
POS 10240	245	500	1.0
POS 15240	245	500	1.5
POS 20240	245	500	2.0
POS 25240	245	500	2.5
POS 30240	245	500	3.0

# BRO-MET®



wrapped bronze sliding bearing, lubrication pockets, low-maintenance

# BRO-MET®/L



wrapped bronze sliding bearing, perforations, low-maintenance

Wrapped bronze sliding bearing, with lubrication pockets •  
Low-maintenance • DIN 1494 / ISO 3547

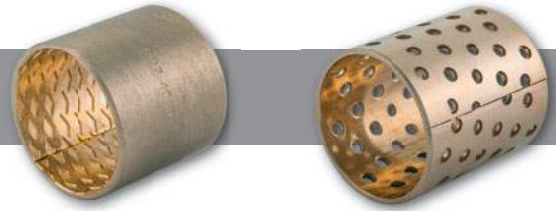

	<b>PROPERTIES</b>	Good load capacity and stability at low abrasion, suited for rough operation, corrosion resistant.
<b>BRO-MET®</b>	<b>MATERIALS</b>	CuSn8P (DIN 17662)
<b>Cylindrical bushing</b>	<b>MATERIAL PROPERTIES</b>	<p>Specific load capacity static ≤ 120 [ N/mm<sup>2</sup> ]</p> <p>Specific load capacity dynamic ≤ 40 [ N/mm<sup>2</sup> ] at max. 2.0 m/s</p> <p>Sliding speed ≤ 2.5 [ m/s ]</p> <p>Friction value 0.05 – 0.12 [ μ ] depending on lubrication</p> <p>Temperature strain -40 – +250 [ °C ]</p> <p>Max. p<sub>v</sub> - value 2.8 [ N/mm<sup>2</sup> x m/s ]</p> <p>Percentage contact area (BRO-MET®) &gt; 75 [ % ]</p>
<b>BMZ</b>	<b>TOLERANCE DETAILS</b>	<p>Housing Ø H7</p> <p>Bushing Inner Ø after mounting H9</p> <p>Shaft tolerance f7 or h8</p>
<b>Flange bushing</b>	<b>SHAFT MATERIAL</b>	Steel, hardened or untempered, surface roughness R <sub>a</sub> < 0.8 μm
<b>BMB</b>	<b>MOUNTING ADVICE</b>	<p>Housing Mounting chamfer, min. 1.5 mm x 15-45°</p> <p>Shaft Mounting chamfer, 5 mm x 15°, edges rounded</p> <p>Force fitting mandrel Application of an adequate force fitting mandrel is advisable. Grease lubrication of the outer surface may be necessary when mounting.</p>
<b>Thrust washer</b>	<b>MAINTENANCE</b>	BRO-MET® and BRO-MET®/L are low-maintenance bronze sliding bearings, primary lubrication is necessary. Oil or grease lubrication is possible. Due to lubrication pockets lubrication intervals are reduced to a minimum!
<b>BMA</b>		
<b>Strips</b>		
<b>BMS</b>		
<b>BRO-MET® /L</b>		
<b>Cylindrical bushing</b>		
<b>BMZ/L</b>		
<b>Flange bushing</b>		
<b>BMB/L</b>		
<b>Strips</b>		
<b>BMS/L</b>		

We produce all special designs at short notice! Additional lubrication slots or lubrication drills are available on demand! Cylindrical and flange bushings, thrust washer and strips are standard fabrication.

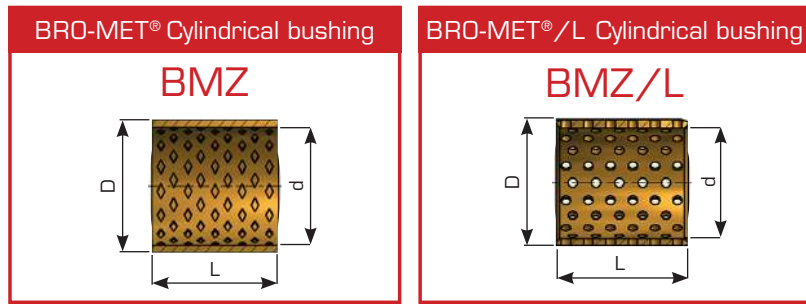

	L	6	8	10	12	15	20	25	30	35	40	50	60	70
d	D													
06	08		0608	0610										
08	10		0808	0810	0812									
10	12	1006		1010	1012	1015	1020							
12	14		1208	1210	1212	1215	1220							
13	15					1315	1320							
14	16			1410	1412	1415	1420	1425						
15	17		1508	1510	1512	1515	1520	1525						
16	18			1610	1612	1615	1620	1625						
17	19					1715	1720							
18	20			1810A		1815A	1820A	1825A	1830A					
18	21					1815B	1820B		1830B					
20	22						2020A	2025A	2030A					
20	23						2020B	2025B	2030B		2040B			
22	25					2215	2220	2225	2230		2240			
24	27					2415A	2420A	2425A	2430A		2440A			
24	28					2415B	2420B	2425B	2430B					
25	28					2515	2520	2525	2530		2540	2550		
28	31					2815A	2820A	2825A	2830A					
28	32					2815B	2820B	2825B	2830B		2840B			
30	34			3010	3012	3015	3020	3025	3030		3040	3050		
32	36					3215	3220	3225	3230		3240	3250		
35	39			3510		3515	3520	3525	3530		3540	3550		
38	42							3825	3830		3840	3850	3860	
40	44					4015	4020	4025	4030	4035	4040	4050	4060	4070
42	46						4220		4230					
45	50						4520		4530		4540	4550	4560	
50	55			5010		5015	5020	5025	5030	5035	5040	5050	5060	5070
55	60					5515	5520	5525	5530	5535	5540	5550	5560	5570

	L	20	30	40	50	60	70	80	90	100	120	130	140	150
d	D													
60	65	6020	6030	6040	6050	6060	6070	6080	6090					
65	70	6520	6530	6540	6550	6560	6570	6580	6590					
70	75	7020	7030	7040	7050	7060	7070	7080	7090					
75	80		7530	7540	7550	7560	7570	7580	7590					
80	85	8020	8030	8040	8050	8060	8070	8080	8090	80100				
85	90		8530	8540	8550	8560	8570	8580	8590					
90	95		9030	9040	9050	9060	9070	9080	9090	90100	90120			
95	100			9540	9550	9560	9570	9580	9590	95100				
100	105	10020	10030	10040	10050	10060	10070	10080	10090	100100	100120			
105	110				10550	10560	10570	10580	10590	105100				
110	115		11030		11050	11060	11070	11080	11090	110100				
115	120			11540	11550	11560	11570	11580	11590	115100				
120	125				12050	12060	12070	12080	12090					
125	130					12560	12570	12580	12590	125100				
130	135			13040	13050	13060	13070	13080	13090	130100	130120			
135	140					13560	13570	13580	13590		135120			
140	145				14050	14060	14070	14080	14090	140100	140120			
150	155					15060	15070	15080	15090	150100				
160	165					16060	16070	16080	16090	160100	160120	160130	160140	160150
170	175					17060	17070	17080	17090	170100	170120	170130	170140	170150
180	185					18060	18070	18080	18090	180100	180120	180130	180140	180150



	L					60	70	80	90	100	120	130	140	150
d	D													
200	205					20060	20070	20080	20090	200100	200120	200130	200140	200150
220	225					22060	22070	22080	22090	220100	220120	220130	220140	220150
250	255					25060	25070	25080	25090	250100	250120	250130	250140	250150
300	305					30060	30070	30080	30090	300100	300120	300130	300140	300150

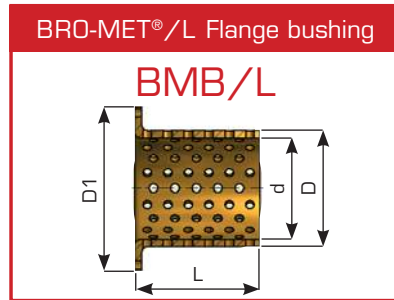
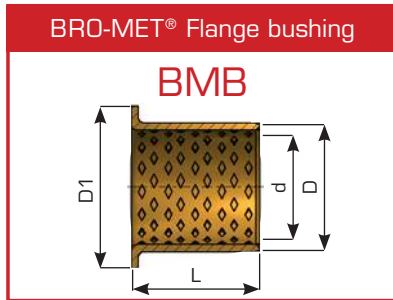

d	D	D <sub>1</sub>	L	11.5	15	16	16.5	20	21.5	25	26	30	35	40
d	D	D <sub>1</sub>	Flange thickness											
20	23	30	1.5	2011,5	2015	2016		2020		2025				
25	28	35	1.5		2515		2516.5	2520	2521.5	2525		2530		
30	34	42	2		3015			3020		3025	3026	3030		3040
32	36	46	2									3230		
35	39	47	2		3515			3520			3526	3530	3535	3540
40	44	53	2			4016				4025		4030	4035	4040

d	D	D <sub>1</sub>	L	20	25	30	35	40	50	60	70	80	90	100
d	D	D <sub>1</sub>	Flange thickness											
45	50	58	2.5	4520		4530		4540	4550					
50	55	65	2.5		5025	5030		5040	5050	5060				
55	60	70	2.5			5530		5540	5550	5560				
60	65	75	2.5			6030	6035	6040	6050	6060				
65	70	80	2.5			6530		6540	6550	6560				
70	75	85	2.5					7040	7050	7060	7070			
80	85	95	2.5			8030	8035	8040	8050	8060	8070	8080		
85	90	100	2.5											
90	95	110	2.5						9050	9060	9070	9080	9090	
100	105	120	2.5	10020				10035	10040	10050	10060	10070	10090	100100
110	115	130	2.5					11035	11040	11050	11060	11070	11090	110100
120	125	150	2.5						12050	12060	12070		12090	120100
130	135	155	2.5							13060			13090	
140	145	165	2.5							14060			14090	
150	155	180	2.5							15060	15070	15080	15090	
160	165	190	2.5							16060	16070	16080	16090	160100
180	185	215	2.5							18060			18090	180100
190	195	225	2.5							19060	19070	19080	19090	190100
200	205	235	2.5							20060	20070	20080	20090	200100
250	255	290	2.5						25050				25090	
300	305	340	2.5							30060			30090	

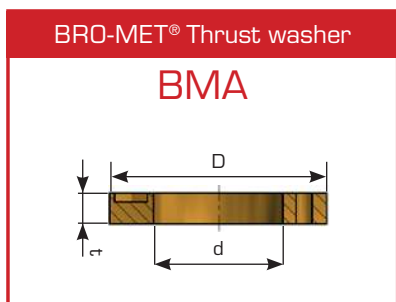

Art. Nr.	d	D	t
BMA 10/1	10	20	1.5
BMA 12/1	12	24	1.5
BMA 14/1	14	26	1.5
BMA 16/1	16	30	1.5
BMA 18/1	18	32	1.5
BMA 20/1	20	36	1.5
BMA 22/1	22	38	1.5
BMA 24/1	24	42	1.5
BMA 26/1	26	44	1.5
BMA 28/1	28	48	1.5
BMA 32/1	32	54	1.5
BMA 38/1	38	62	1.5
BMA 42/1	42	66	1.5
BMA 48/2	48	74	2
BMA 52/2	52	78	2
BMA 62/2	62	90	2

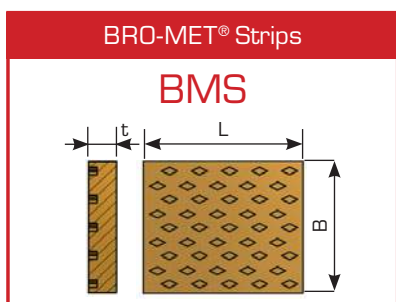

Art. Nr.	B	L	t
BMS 10240	245	500	1.0
BMS 15240	245	500	1.5
BMS 20240	245	500	2.0
BMS 25240	245	500	2.5
BMS 30240	245	500	3.0

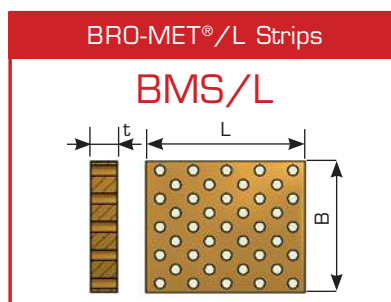

Art. Nr.	B	L	t
BMS/L 10240	245	500	1.0
BMS/L 15240	245	500	1.5
BMS/L 20240	245	500	2.0
BMS/L 25240	245	500	2.5
BMS/L 30240	245	500	3.0

# BIV-MET®



wrapped composite sliding bearing, steel/bronze, lubrication pockets,  
low-maintenance

Wrapped composite sliding bearing steel / bronze with lubrication pockets  
 Low-maintenance • DIN 1494 / ISO 3547



<b>BIV-MET®</b>  <b>Cylindrical bushing</b>  <b>BIZ</b>  <b>Thrust washer</b>  <b>BIA</b>  <b>Strips</b>  <b>BIS</b>	<h2>PROPERTIES</h2> <p>For high load capacity and oscillating movements, as well as for rough operation and temperature load. Long-run lubrication because of lubricant storages.</p>
	<h2>MATERIALS</h2> <p>Support material Steel copper-plated / tin-plated          Sliding layer CuPb10Sn10</p>
	<h2>MATERIAL PROPERTIES</h2> <p>Specific load capacity static <math>\leq 250</math> [ N/mm<sup>2</sup> ]          Specific load capacity dynamic <math>\leq 140</math> [ N/mm<sup>2</sup> ]          Sliding speed <math>\leq 2.5</math> [ m/s ] oil lubricated <math>\leq 5</math>m/s          Friction value 0.04 – 0.12 [ <math>\mu</math> ] depending on lubrication          Temperature strain -40 – +250 [ °C ]          Max. <math>p_v</math> - value 2.8 [ N/mm<sup>2</sup> x m/s ]          Percentage contact area <math>&gt; 75</math> [ % ]</p>
	<h2>TOLERANCE DETAILS</h2> <p>Housing <math>\varnothing</math> H7          Bushing Inner <math>\varnothing</math> after mounting H9          Shaft tolerance f7</p>
	<h2>SHAFT MATERIAL</h2> <p>Steel, hardened or untempered, surface roughness <math>R_a &lt; 0.8 \mu\text{m}</math></p>
	<h2>MOUNTING ADVICE</h2> <p>Housing Mounting chamfer, min. 1.5 mm x 15-45°          Shaft Mounting chamfer, 5 mm x 15°, edges rounded          Force fitting mandrel Application of an adequate force fitting mandrel is advisable. Grease lubrication of the outer surface may be necessary when mounting.</p>
	<h2>MAINTENANCE</h2> <p>BIV-MET® is a low-maintenance composite sliding bearing, but primary lubrication is necessary. Oil or grease lubrication is possible. Due to lubrication pockets, lubrication is reduced to a minimum.</p>

We produce all special designs at short notice! Flange bushings, punchings and moldings are produced on customer's requirement. Additional lubrication slots or lubrication drills are available on demand! Cylindrical bushings, thrust washer and strips are standard fabrication.

BIV-MET® Cylindrical bushing

**BIZ**

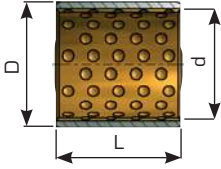

	L	10	15	20	25	30	40	50	60	80	90	100
d	D											
10	12	1010	1015	1020								
12	14	1210	1215	1220								
14	16	1410	1415	1420								
15	17	1510	1515	1520								
16	18	1610	1615	1620								
18	20	1810	1815	1820	1825							
20	23	2010	2015	2020	2025							
22	25	2210	2215	2220	2225							
24	27	2410	2415	2420		2430						
25	28		2515	2520	2525	2530						
26	30		2615	2620	2625	2630						
28	32		2815	2820	2825	2830	2840					
30	34		3015	3020	3025	3030	3040					
32	36		3215	3220	3225	3230	3240					
35	39			3520	3525	3530	3540	3550				
38	42			3820	3825	3830	3840	3850				
40	44			4020	4025	4030	4040	4050				
45	50			4520	4525	4530	4540	4550				
50	55					5030	5040	5050	5060			
55	60					5530	5540	5550	5560			
60	65					6030		6050	6060			
65	70					6530	6540	6550	6560			
70	75					7030	7040	7050	7060	7080		
75	80					7530	7540	7550	7560			
80	85						8040	8050	8060	8080		
85	90						8540	8550	8560	8580		
90	95						9040	9050	9060	9080		
95	100							9550	9560	9580	9590	
100	105							10050	10060	10080	10090	
105	110							10550	10560	10580		
110	115							11050	11060	11080		
115	120							11550	11560	11580		
120	125							12050	12060	12080		
125	130							12550	12560	12580		125100
130	135								13060	13080		130100
135	140								13560	13580		135100
140	145								14060	14080		140100
150	155								15060	15080	15090	
160	165								16060	16080		160100
170	175								17060	17080		170100
175	180								17560	17580		175100

BIV-MET® Thrust washer

**BIA**

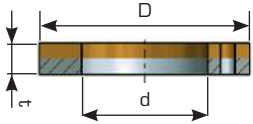

BIV-MET® Strips

**BIS**

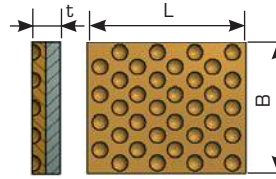

Art. Nr.	d	D	t
BIA 10/1	10	20	1.5
BIA 12/1	12	24	1.5
BIA 14/1	14	26	1.5
BIA 16/1	16	30	1.5
BIA 18/1	18	32	1.5
BIA 20/1	20	36	1.5
BIA 22/1	22	38	1.5
BIA 24/1	24	42	1.5
BIA 26/1	26	44	1.5
BIA 28/1	28	48	1.5
BIA 32/1	32	54	1.5
BIA 38/1	38	62	1.5
BIA 42/1	42	66	1.5
BIA 48/2	48	74	2
BIA 52/2	52	78	2
BIA 62/2	62	90	2

Art. Nr.	B	L	t
BIS 10240	245	500	1.0
BIS 15240	245	500	1.5
BIS 20240	245	500	2.0
BIS 25240	245	500	2.5
BIS 30240	245	500	3.0

# BRO-LUB®



wrapped bronze sliding bearing, solid lubricant, maintenance-free

# BIV-LUB®



wrapped composite sliding bearing, steel/bronze, solid lubricant, maintenance-free

Wrapped bronze sliding bearing • Solid lubricant pockets •  
 Maintenance-free • DIN 1494 / ISO 3547

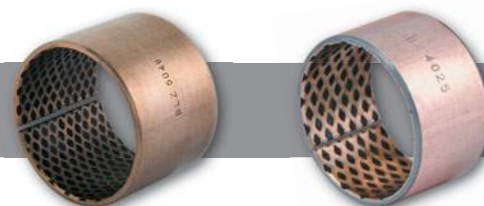

	<b>PROPERTIES</b>	High load capacity and stability at low abrasion, excellent suitable at low sliding speeds and oscillating movements.	
<b>BRO-LUB®</b>	<b>MATERIALS</b>	<b>BRO-LUB®</b>	<b>BIV-LUB®</b>
<b>Cylindrical bushing</b>	Support material	CuSn8P (DIN 17662)	Steel copper-plated
<b>BLZ</b>	Sliding layer		CuPb10Sn10
	Solid lubricant	Lubrication pockets are filled with graphite.	Lubrication pockets are filled with graphite.
<b>Thrust washer</b>	<b>MATERIAL PROPERTIES</b>		
<b>BLA</b>	Specific load capacity static	≤ 120 [ N/mm <sup>2</sup> ]	≤ 200 [ N/mm <sup>2</sup> ]
	Specific load capacity dynamic	≤ 40 [ N/mm <sup>2</sup> ]	≤ 75 [ N/mm <sup>2</sup> ]
<b>Strips</b>	Sliding speed	≤ 0.4 [ m/s ]	≤ 0.4 [ m/s ]
<b>BLS</b>	Friction value	0.03 – 0.25 [ μ ]	0.08 – 0.22 [ μ ]
	Temperature strain	-100 – +200 [ °C ]	-100 – +200 [ °C ]
<b>BIV-LUB®</b>	Max. p <sub>v</sub> - value	1.5 [ N/mm <sup>2</sup> x m/s ]	1.5 [ N/mm <sup>2</sup> x m/s ]
<b>Cylindrical bushing</b>	<b>TOLERANCE DETAILS</b>		
<b>BUZ</b>	Housing Ø	H7	
	Bushing Inner Ø after mounting	H9	
<b>Thrust washer</b>	Shaft tolerance	f7	
<b>BUA</b>	<b>SHAFT MATERIAL</b>	Steel, hardened or untempered, surface roughness R <sub>a</sub> < 0.8 μm	
<b>Strips</b>	<b>MOUNTING ADVICE</b>		
<b>BUS</b>	Housing	Mounting chamfer, min. 1.5 mm x 15-45°	
	Shaft	Mounting chamfer, 5 mm x 15°, edges rounded	
	Force fitting mandrel	Application of an adequate force fitting mandrel is advisable. Grease lubrication of the outer surface may be necessary when mounting.	
	<b>MAINTENANCE</b>	BRO-LUB® and BIV-LUB® are maintenance-free bronzed sliding bearing with solid lubricant pockets, but primary lubrication is necessary! Therefore an ageing resistant lithium-stiffened grease should be used.	

We produce all special designs at short notice! Cylindrical bushings, thrust washer and strips are standard fabrication. Punchings and moldings are produced on customer's requirement.



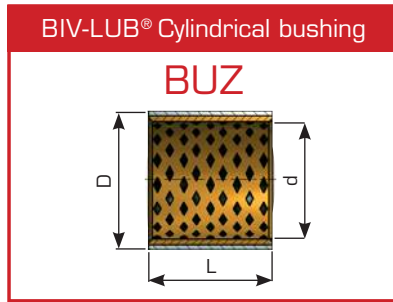
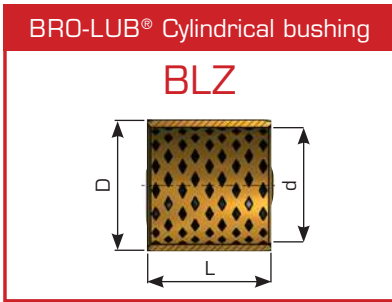

	L	10	15	20	25	30	40	50	60	80	90	100
d	D											
10	12	1010	1015	1020								
12	14	1210	1215	1220								
14	16	1410	1415	1420								
15	17	1510	1515	1520								
16	18	1610	1615	1620								
18	20	1810	1815	1820	1825							
20	23	2010	2015	2020	2025							
22	25	2210	2215	2220	2225							
24	27	2410	2415	2420		2430						
25	28		2515	2520	2525	2530						
26	30		2615	2620	2625	2630						
28	32		2815	2820	2825	2830	2840					
30	34		3015	3020	3025	3030	3040					
32	36		3215	3220	3225	3230	3240					
35	39			3520	3525	3530	3540	3550				
38	42			3820	3825	3830	3840	3850				
40	44			4020	4025	4030	4040	4050				
45	50			4520	4525	4530	4540	4550				
50	55					5030	5040	5050	5060			
55	60					5530	5540	5550	5560			
60	65					6030		6050	6060			
65	70					6530	6540	6550	6560			
70	75					7030	7040	7050	7060	7080		
75	80					7530	7540	7550	7560			
80	85						8040	8050	8060	8080		
85	90						8540	8550	8560	8580		
90	95						9040	9050	9060	9080		
95	100							9550	9560	9580	9590	
100	105							10050	10060	10080	10090	
105	110							10550	10560	10580		
110	115							11050	11060	11080		
115	120							11550	11560	11580		
120	125							12050	12060	12080		
125	130							12550	12560	12580		125100
130	135								13060	13080		130100
135	140								13560	13580		135100
140	145								14060	14080		140100
150	155								15060	15080	15090	
160	165								16060	16080		160100
170	175								17060	17080		170100
175	180								17560	17580		175100

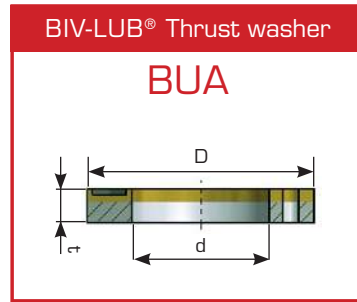
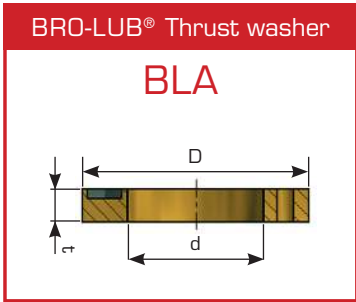

Art. Nr.	d	D	t
BLA 10/1	10	20	1.5
BLA 12/1	12	24	1.5
BLA 14/1	14	26	1.5
BLA 16/1	16	30	1.5
BLA 18/1	18	32	1.5
BLA 20/1	20	36	1.5
BLA 22/1	22	38	1.5
BLA 24/1	24	42	1.5
BLA 26/1	26	44	1.5
BLA 28/1	28	48	1.5
BLA 32/1	32	54	1.5
BLA 38/1	38	62	1.5
BLA 42/1	42	66	1.5
BLA 48/2	48	74	2
BLA 52/2	52	78	2
BLA 62/2	62	90	2

Art. Nr.	d	D	t
BUA 10/1	10	20	1.5
BUA 12/1	12	24	1.5
BUA 14/1	14	26	1.5
BUA 16/1	16	30	1.5
BUA 18/1	18	32	1.5
BUA 20/1	20	36	1.5
BUA 22/1	22	38	1.5
BUA 24/1	24	42	1.5
BUA 26/1	26	44	1.5
BUA 28/1	28	48	1.5
BUA 32/1	32	54	1.5
BUA 38/1	38	62	1.5
BUA 42/1	42	66	1.5
BUA 48/2	48	74	2
BUA 52/2	52	78	2
BUA 62/2	62	90	2

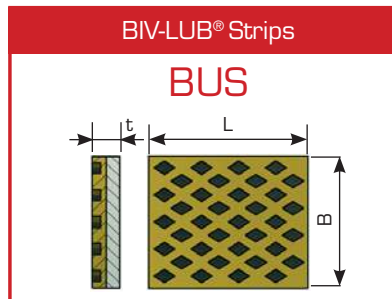
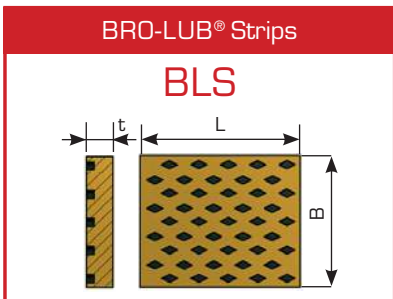

Our strips are custom made for your requirements.

# SIB-MET®



sintered bronze sliding bearing, oil-soaked, self-lubricating

Sintered bronze sliding bearing • Oil-soaked • Self-lubricating •  
DIN 1850 / ISO 2795 as well as other standards



<b>SIB-MET®</b>  <b>Cylindrical bushing</b>  <b>SBZ</b>  <b>Flange bushing</b>  <b>SBB</b>	<b>PROPERTIES</b>	Suitable for high sliding speeds at low load capacity.
	<b>MATERIALS</b>	CuSn10 (equivalent to SINT B50)
	<b>MATERIAL PROPERTIES</b>	Specific load capacity static ≤ 18 [ N/mm <sup>2</sup> ] to 50 N/mm <sup>2</sup> at SINT A51 Specific load capacity dynamic ≤ 5 [ N/mm <sup>2</sup> ] Sliding speed ≤ 6.0 [ m/s ] Friction value 0.05 – 0.20 [ μ ] Temperature strain * -20 – +100 [ °C ] Max. p <sub>v</sub> - value 1.6 [ N/mm <sup>2</sup> x m/s ]
	<b>TOLERANCE DETAILS</b>	Housing Ø H7 Bushing Inner Ø after mounting H7 / H8 Shaft tolerance f7
	<b>SHAFT MATERIAL</b>	Steel, hardness >200HB, surface roughness R <sub>a</sub> < 0.8 μm
Also deliverable as sintered iron!	<b>MOUNTING ADVICE</b>	Application of an adequate force fitting mandrel is advisable.
	<b>MAINTENANCE</b>	SIB-MET® is self-lubricating

\* MoS<sub>2</sub>-sintered bronzed sliding bearings for temperatures up to + 400°C are deliverable on demand. Cylindrical bushings, flange bushings, full pieces, blanks and plates are standard fabrication.  
We produce all special designs at short notice!

SIB-MET® Cylindrical bushing

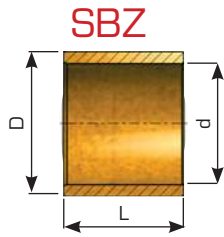

	L	02	03	04	05	06	08	10	12	14	15	16	20
d	D												
02	04			020404		020406							
02	05	020502	020503		020505								
03	06		030603	030604	030605	030606		030610					
04	06				040605		040608	040610					
04	07			040704		040706	040708		040712				
04	08			040804	040805	040806	040808	040810	040812				
04	10						041008						
05	08				050805	050806	050808	050810	050812		050815	050816	
05	09			050904	050905		050908	050910			051015		
05	10				051005		051008	051010	051012				
06	08					060806		060810	060812		060815		
06	09			060904		060906	060908	060910	060912		060915		
06	10			061004	061005	061006		061010	061012		061015	061016	
06	12				061205	061206	061208		061212		061215	061216	
06	14								061412				
07	10				071005	071006	071008	071010					
08	10					081006		081010	081012		081015		
08	11						081108		081112			081116	081120
08	12					081206	081208	081210	081212		081215	081216	081220
08	14					081406	081408	081410	081412		081415	081416	081420
09	12					091206		091210		091214	091215		
09	14							091410	091412		091415		091420
10	12						101208						

	L	06	08	10	12	14	15	16	18	20	22	25	28
d	D												
10	13		101308	101310		101314	101315			101320		101325	
10	14	101406	101408		101412	101414	101415			101420		101425	
10	15		101508	101510		101514	101515		101518		101522		
10	16	101606	101608	101610		101614	101615		101618		101622		
10	18		101808			101814			101818		101822		
10	20										102022		
10	22								102218				
12	14		121408	121410		121414			121418				
12	15		121508	121510		121514	121515		121518		121522		
12	16	121606	121608	121610		121614	121615		121618		121622		
12	17			121710		121714	121715		121718		121722		
12	18	121806	121808	121810		121814	121815		121818		121822		121828
12	20			122010		122014			122018		122022		122028
13	15												
13	20					132014					132022		
14	18		141808		141812	141814		141816	141818	141820	141822	141825	
14	20		142008		142012	142014		142016	142018	142020	142022	142025	142028
14	22					142214			142218		142222		
15	18					151814			151818		151822		151828
15	19		151908			151914	151915		151918		151922		
15	20					152014			152018		152022		152028

	L	12	15	16	18	20	22	25	28	30	32	35	36
d	D												
15	21		152115	152116		152120		152125			152132		
15	22		152215	152216		152220		152225		152230			
16	20	162012	162015	162016		162020		162025		162030			
16	22	162212	162215	162216		162220		162225		162230	162232		
16	24		162415	162416		162420			162428				
17	22		172215			172220		172225		172230		172235	
18	22	182212	182215		182218	182220	182222	182225	182228	182230			182236
18	24	182412			182418	182420	182422		182428	182430			182436
18	25			182516	182518	182520	182522	182525	182528	182530	182532	182535	182536
20	24			202416		202420		202425			202432		
20	25		202515	202516		202520		202525		202530	202532	202535	

	L	15	20	25	28	30	32	35	40	45	50	60	70
d	D												
20	26	202615	202620	202625		202630	202632	202635	202640				
20	27		202720	202725			202732						
20	28	202815	202820	202825		202830	202832	202835	202840		202850		
20	30		203020	203025		203030		203035	203040				
22	27	222715	222720	222725	222728	222730							
22	28		222820	222825		222830			222840				
22	29												
22	32		223220	223225		223230							
25	30		253020	253025		253030	253032	253035	253040				
25	32	253215	253220	253225		253230	253232	253235	253240	253245			
25	35			253525		253530		253535	253540	253545	253550		
28	32				283228								
28	36			283625	283628					283645			
30	35		303520	303525		303530		303535	303540		303550		
30	38		303820	303825		303830	303832	303835	303840		303850		
30	40		304020			304030		304035	304040	304045	304050	304060	
32	38		323820	323825			323832		323840		323850		
32	40		324020	324025		324030	324032		324040		324050		
35	40		354020			354030			354040		354050		
35	44				354428				354450				
35	45			354525		354530		354535	354540		354550	354560	354570
36	42				364228								
40	45								404540		404550		
40	46			404625		404630			404640				
40	50			405025		405030			405040		405050		405070
45	51				455128								
45	55							455535					
45	56												
45	60								456040				
50	56						505632						
50	60						506032	506035	506040		506050	506060	506070
50	70												507070
55	65								556540				556570
60	68										606850	606860	606870
60	70										607050	607060	
60	72										607250	607260	
63	70								637040		637050		

	L	60	70	80	90	100	120
d	D						
70	80	708060	708070		708090		
70	85	708560			708590		
75	90		759070				
80	90		809070				
80	95		809570				
80	100						80100120
85	95					8595100	
90	105			9010580			
90	110			9011080			
100	120			10012080			100120120
110	125					110125100	110125120
125	150		12515070				125150120

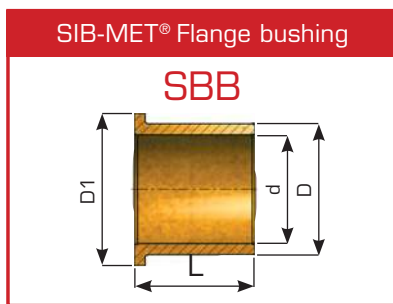

d	D	D <sub>1</sub>	L	Flange thickness	04	05	06	08	10	12	14	15	16	20
03	06	09	1,5		030604		030606		030610					
04	08	10	2				040806B							
04	08	12	2		040804	040805	040806	040808	040810	040812				
05	09	13	2		050904	050905		050908						
06	10	14	2		061004A		061006A		061010A					
06	12	14	2				061206							
08	12	14	2								081214			
08	12	16	2				081206	081208	081210	081212		081215	081216	
08	14	18	3					081408						
09	14	19	2,5						091410					
10	13	16	1,5						101310				101316	101320
10	14	18	2						101410A			101415A		101420A
10	15	20	2,5						101510A				101516A	101520A
10	15	20	3						101510B			101515B		101520B
10	16	20	2									101615A		101620

d	D	D <sub>1</sub>	L	Flange thickness	08	10	12	14	15	16	18	20	22	25
10	16	22	3		101608C	101610C				101616				
12	15	18	1,5				121512			121516		121520		
12	16	18	2									121620		
12	16	20	3						121615					
12	17	22	3			121710B						121720B		121725B
12	17	22	2,5				121712A			121716A				121725A
12	18	22	3			121810A	121812A							
12	18	24	3		121808C		121812C					121820C		
14	18	22	2			141810		141814			141818		141822	
14	20	25	3						142015A			142020A		142025A
14	20	26	3			142010B		142014B					142022B	
15	19	23	2							151916		151920		
15	20	25	3						152015					152025A
15	20	25	2									152020B		
15	21	26	5							152116A				
15	21	27	3			152110				152116		152120		152125

	L	12	15	16	18	20	22	25	28	30	32		
d	D	D <sub>1</sub>	Flange thickness										
16	20	24	2	162012				162020		162025			
16	22	28	3	162212A	162215A	162216A		162220A		162225A		162230	162232
18	22	26	2						182222		182228		
18	24	30	3	182412			182418A		182422A		182428A	182430A	
18	25	32	4	182512									
20	24	28	2			202416		202420		202425			
20	26	32	3		202615A	202616A		202620A		202625A		202630A	202632A
20	28	35	4			202816		202820				202830	
22	27	32	2,5				222718		222722				
22	28	33	4		222815B								
22	28	34	3				222818						
25	30	35	2,5					253020		253025			253032
25	32	38	6							253225C			
25	32	39	3,5					253220A		253225A		253230A	253232A

	L	16	20	22	25	28	30	32	35	36	40	
d	D	D <sub>1</sub>	Flange thickness									
25	32	40	4				253225B		253230B			253240B
25	35	45	5	253516			253525					
28	33	38	2,5			283322		283328				
28	36	44	4			283622		283628			283636	
30	38	44	6						303832A			
30	38	46	4		303820		303825		303830			
30	40	48	4				304025		304030A			
30	40	50	5		304020				304030			
32	38	44	3		323820					323832		
32	40	46	6									
32	40	48	4				324025		324030	324032		
35	45	55	5		354520		354525		354530		354535	354540
36	42	48	3			364222		364228				
36	45	54	4,5			364522					364536	
40	46	52	3				404625					404640
40	50	58	6									405040C

	L	25	30	32	35	40	45	50	60	63	80	
d	D	D <sub>1</sub>	Flange thickness									
40	50	60	5	405025A	405030A	405032A	405035A	405040A		405050A		
45	51	57	3					455145				
45	55	65	5				455535A	455545A				
50	56	62	3			505632		505640		505650		
50	60	68	5				506035		506045		506060	
50	60	68	7							506050		
50	60	70	5			506032A		506040		506050A		
60	70	80	5							607050	607060	
60	72	84	6							607250	607260	607263
60	75	85	8								607560	
70	85	95	8							708560		
90	110	120	8						9011050			
100	120	130	8									10012080



# COM-KU<sup>®</sup>/D spherical



spherical plain bearing, stainless steel with COM-KU<sup>®</sup>/D sliding layer,  
maintenance-free and corrosion-free

# COM-KU®/D Ball

## LD series

Dimension (mm)				Load Rating	
d	d <sub>k</sub>	B	b	C (kN)	C <sub>0</sub> (kN)
16	28	16	14	24	47
20	33	20	18	36	71
25	44	26	22	58	116
32	48	26	22	63	127
35	55	32	26	86	172
40	60	32	28	101	202
50	75	50	45	203	405
60	90	60	50	270	540
70	100	65	60	360	720
80	110	70	60	396	792
90	125	80	70	525	1,050
100	140	90	80	672	1,344
110	155	100	90	837	1,674
125	166	100	90	896	1,793
140	194	125	110	1,280	2,561
150	210	140	130	1,638	3,276
160	225	150	140	1,890	3,780
180	250	160	150	2,250	4,500
200	290	190	180	3,132	6,264

C = dynamic load rating

C<sub>0</sub> = static load rating

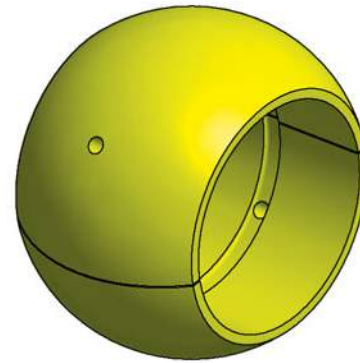

- LD type is a cost effective spherical bearing fully made of COM-KU®/D
- Typically used in hydraulic cylinder heads
- Applicable in sea-water and most light chemicals
- Bearing size can be fully customized
- Periodic lubrication is required if installed in hydraulic cylinder eyes (to prevent corrosion of mating steel surface)
- Split-line of bearing has to be positioned about 90° from main force direction

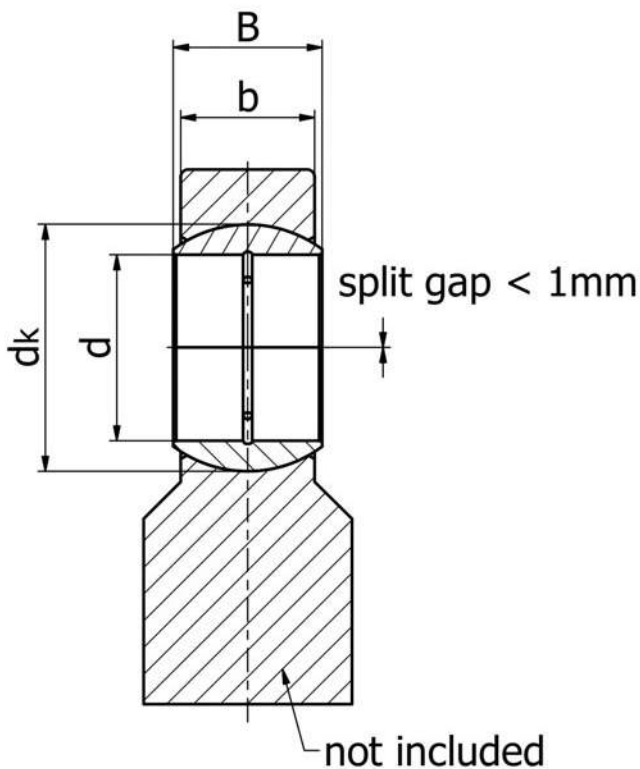

**COM-KU®/D Spherical • Floating & fixed bearing**

**ND, ND-s series**

Dimension (mm)					Load Rating ND	
d	dk	D	b	B	C (KN)	C <sub>0</sub> (KN)
20	29	35	12	16	28	52
25	35.5	42	16	20	45	85
30	40.7	47	18	22	59	110
35	47	55	20	25	75	141
40	53	62	22	28	93	175
45	60	68	25	32	120	225
50	66	75	28	35	148	277
60	80	90	36	44	230	432
70	92	105	40	49	294	552
80	105	120	45	55	378	709
90	115	130	50	60	460	863
100	130	150	55	70	572	1,073
110	140	160	55	70	616	1,155
120	160	180	70	85	896	1,680
140	180	210	70	90	1,008	1,890
160	200	230	80	105	1,280	2,400
180	225	260	80	105	1,440	2,700
200	250	290	100	130	2,000	3,750
220	275	320	100	135	2,200	4,125
240	300	340	100	140	2,400	4,500
260	325	370	110	150	2,860	5,363
280	350	400	120	155	3,360	6,300
300	375	430	120	155	3,600	6,750
320	380	440	135	160	4,104	7,695
340	400	460	135	160	4,320	8,100
360	420	480	135	160	4,536	8,505
380	450	520	160	190	5,760	10,800
400	470	540	160	190	6,016	11,280
420	490	560	160	190	6,272	11,760
440	520	600	185	218	7,696	14,430
460	540	620	185	218	7,992	14,985
480	565	650	195	230	8,814	16,526
500	585	670	195	230	9,126	17,111
530	620	710	205	243	10,168	19,065
560	655	750	215	258	11,266	21,124
600	700	800	230	272	12,880	24,150
630	740	850	260	300	15,392	28,860
670	785	900	260	308	16,328	30,615
710	830	950	275	325	18,260	34,238
750	875	1000	280	335	19,600	36,750
800	930	1060	300	355	22,320	41,850
850	985	1120	310	365	24,428	45,803
900	1040	1180	320	375	26,624	49,920
950	1100	1250	340	400	29,920	56,100
1000	1160	1320	370	438	34,336	64,380

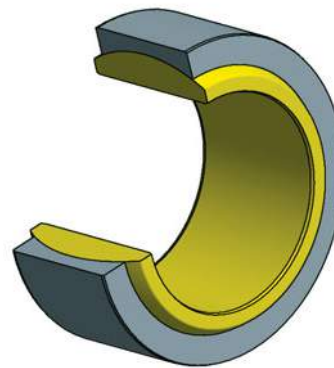
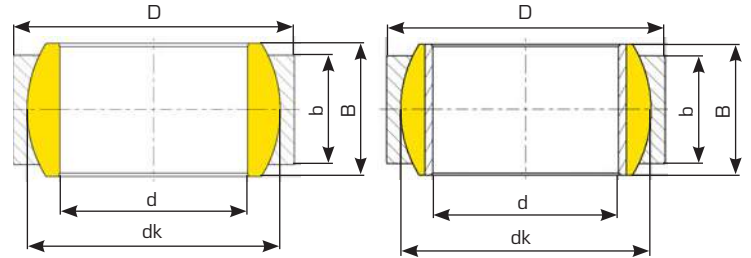

**FLOATING BEARING  
ND-s type [LL]**

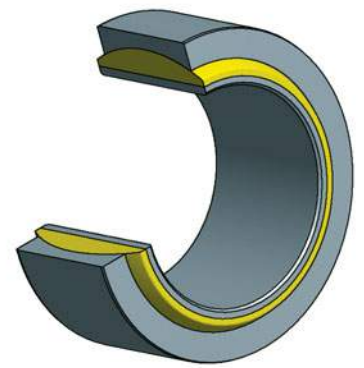

**FIXED BEARING  
ND type [FL]**

- ND-s type is designed with stainless steel outer ring and a COM-KU®/D inner sphere
- ND type is designed with a stainless steel outer ring and a COM-KU®/D inner sphere with an additional stainless steel sleeve
- Maintenance-free (no additional lubrication required)
- Applicable in sea-water and most light chemicals
- Bearing size in this chart is compatible with standard "GE" bearings
- For contaminated applications, the bearing can be produced with sealing
- Apart from typical oscillating movements, it is also suitable for micromovements (<1°)
- Custom bearings with greater tilting angles, higher load ratings, multiple force directions, etc. are possible

C = dynamic load rating

C<sub>0</sub> = static load rating

## COM-KU®/D Spherical • Floating & fixed bearing

### ND-X, ND-Xs series

Dimension (mm)					Load Rating ND	
d	dk	D	b	B	LL & FL	
					C (KN)	C <sub>0</sub> (KN)
100	130	150	55	70	858	2,002
110	140	160	55	70	924	2,156
120	160	180	70	85	1,344	3,136
140	180	210	70	90	1,512	3,528
160	200	230	80	105	1,920	4,480
180	225	260	80	105	2,160	5,040
200	250	290	100	130	3,000	7,000
220	275	320	100	135	3,300	7,700
240	300	340	100	140	3,600	8,400
260	325	370	110	150	4,290	10,010
280	350	400	120	155	5,040	11,760
300	375	430	120	155	5,400	12,600
320	380	440	135	160	6,156	14,364
340	400	460	135	160	6,480	15,120
360	420	480	135	160	6,804	15,876
380	450	520	160	190	8,640	20,160
400	470	540	160	190	9,024	21,056
420	490	560	160	190	9,408	21,952
440	520	600	185	218	11,544	26,936
460	540	620	185	218	11,988	27,972
480	565	650	195	230	13,221	30,849
500	585	670	195	230	13,689	31,941
530	620	710	205	243	15,252	35,588
560	655	750	215	258	16,899	39,431
600	700	800	230	272	19,320	45,080
630	740	850	260	300	23,088	53,872
670	785	900	260	308	24,492	57,148
710	830	950	275	325	27,390	63,910
750	875	1000	280	335	29,400	68,600
800	930	1060	300	355	33,480	78,120
850	985	1120	310	365	36,642	85,498
900	1040	1180	320	375	39,936	93,184
950	1100	1250	340	400	44,880	104,720
1000	1160	1320	370	438	51,504	120,176

C = dynamic load rating

C<sub>0</sub> = static load rating

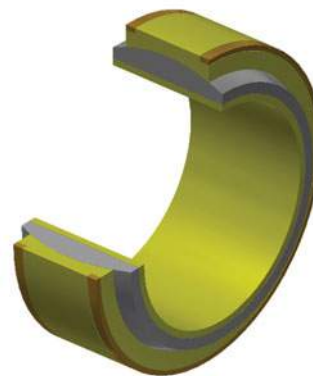
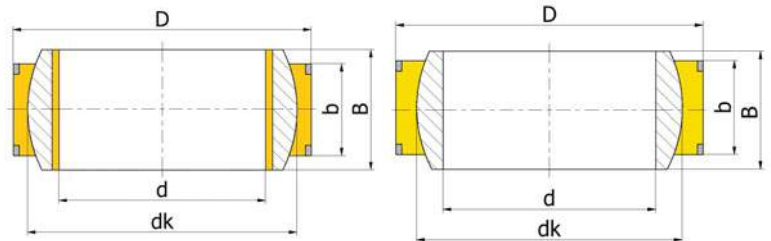

**FLOATING BEARING  
ND-Xs type [LL]**

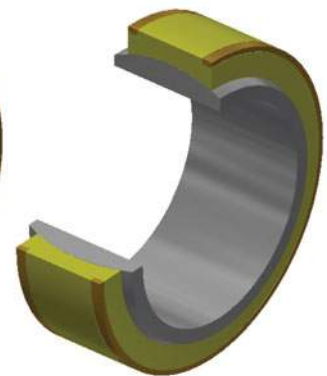

**FIXED BEARING  
ND-X type [FL]**

- ND-Xs type is designed with a COM-KU®/D outer ring and a stainless steel inner sphere
- ND-X type is designed with a COM-KU®/D outer ring and a stainless steel inner sphere with an additional COM-KU®/D sleeve
- ND-X type bearings allow higher bearing forces compared to ND series.
- Maintenance-free (no additional lubrication required)
- Applicable in sea-water and most light chemicals
- Bearing size in this chart is compatible with standard "GE" bearings
- For contaminated applications, the bearing can be produced with sealing
- Apart from typical oscillating movements, it is also suitable for micromovements (<1°)
- Custom bearings with greater tilting angles, higher load ratings, multiple force directions, etc. are possible

# LUB-MET® spherical



spherical plain bearing, LUB-MET® with stainless steel,  
maintenance-free and corrosion-free

# LUB-MET® Spherical • Floating bearing

## ND series

Dimension (mm)					Load Rating ND LL					
					CuSn12		CuAl10Ni		CuZn25Al5	
d	dk	D	b	B	C (KN)	C <sub>0</sub> (KN)	C (KN)	C <sub>0</sub> (KN)	C (KN)	C <sub>0</sub> (KN)
20	29	35	12	16	33	59	61	101	77	128
25	35.5	42	16	20	53	97	99	165	126	210
30	40.7	47	18	22	69	125	127	213	163	270
35	47	55	20	25	88	160	164	274	209	347
40	53	62	22	28	110	198	203	339	259	430
45	60	68	25	32	141	255	261	437	333	554
50	66	75	28	35	174	314	322	538	410	682
60	80	90	36	44	271	490	501	838	639	1,063
70	92	105	40	49	346	626	640	1,071	817	1,358
80	105	120	45	55	444	803	822	1,375	1,049	1,744
90	115	130	50	60	541	978	1,001	1,673	1,277	2,122
100	130	150	55	70	672	1,216	1,244	2,081	1,587	2,638
110	140	160	55	70	724	1,309	1,340	2,241	1,709	2,841
120	160	180	70	85	1,053	1,904	1,949	3,259	2,486	4,133
140	180	210	70	90	1,184	2,142	2,192	3,667	2,797	4,649
160	200	230	80	105	1,504	2,720	2,784	4,656	3,552	5,904
180	225	260	80	105	1,692	3,060	3,132	5,238	3,996	6,642
200	250	290	100	130	2,350	4,250	4,350	7,275	5,550	9,225
220	275	320	100	135	2,585	4,675	4,785	8,003	6,105	10,148
240	300	340	100	140	2,820	5,100	5,220	8,730	6,660	11,070
260	325	370	110	150	3,361	6,078	6,221	10,403	7,937	13,192
280	350	400	120	155	3,948	7,140	7,308	12,222	9,324	15,498
300	375	430	120	165	4,230	7,650	7,830	13,095	9,990	16,605
320	380	440	135	160	4,822	8,721	8,926	14,928	11,389	18,930
340	400	460	135	160	5,076	9,180	9,396	15,714	11,988	19,926
360	420	480	135	160	5,330	9,639	9,866	16,500	12,587	20,922
380	450	520	160	190	6,768	12,240	12,528	20,952	15,984	26,568
400	470	540	160	190	7,069	12,784	13,085	21,883	16,694	27,749
420	490	560	160	190	7,370	13,328	13,642	22,814	17,405	28,930
440	520	600	185	218	9,043	16,354	16,739	27,994	21,356	35,498
460	540	620	185	218	9,391	16,983	17,383	29,071	22,178	36,863
480	565	650	195	230	10,356	18,730	19,170	32,061	24,459	40,655
500	585	670	195	230	10,723	19,393	19,849	33,196	25,325	42,094
530	620	710	205	243	11,947	21,607	22,115	36,986	28,216	46,900
560	655	750	215	258	13,238	23,940	24,504	40,980	31,263	51,964
600	700	800	230	272	15,134	27,370	28,014	46,851	35,742	59,409
630	740	850	260	300	18,086	32,708	33,478	55,988	42,713	70,996
670	785	900	260	308	19,185	34,697	35,513	59,393	45,310	75,313
710	830	950	275	325	21,456	38,803	39,716	66,421	50,672	84,224
750	875	1000	280	335	23,030	41,650	42,630	71,295	54,390	90,405
800	930	1060	300	355	26,226	47,430	48,546	81,189	61,938	102,951
850	985	1120	310	365	28,703	51,910	53,131	88,857	67,788	112,674
900	1040	1180	320	375	31,283	56,576	57,907	96,845	73,882	122,803
950	1100	1250	340	400	35,156	63,580	65,076	108,834	83,028	138,006
1000	1160	1320	370	438	40,345	72,964	74,681	124,897	95,282	158,375

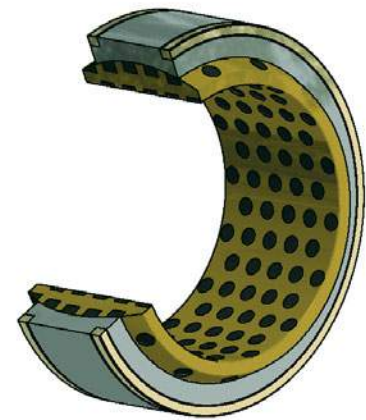
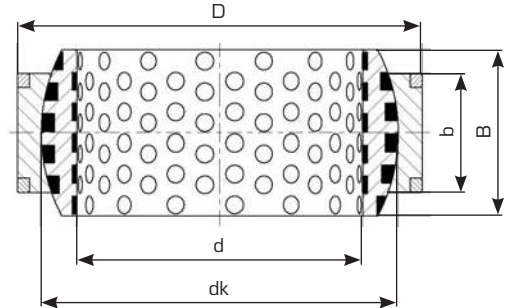

### FLOATING BEARINGS ND type [LL]

The outer bearing ring is fixed with the housing. The spherical surface handles the tilting of the bearing and the rotational movement takes place at the inner diameter of the bearing and allows also for a longitudinal movement.

- Exists of a LUB-MET® inner ring and a stainless steel outer ring.
- Bronze alloy of LUB-MET® and grade of stainless steel will be recommended according to your application requirements
- Sea-water resistant material pairings are available
- Bearings can run completely without lubrication (self-lubricating)
- For contaminated applications, the bearing can be delivered with sealing
- Bearing size in this chart is compatible with standard "GE" bearings
- Custom bearings with greater tilting angles, higher load ratings, multiple force directions, etc. are possible

\*Alloy data sheets can be found on page 6

C = dynamic load rating

C<sub>0</sub> = static load rating

# LUB-MET® Spherical • Fixed bearing

## ND series

Dimension (mm)					Load Rating ND FL					
					CuSn12		CuAl10Ni		CuZn25Al5	
d	dk	D	b	B	C (KN)	C <sub>0</sub> (KN)	C (KN)	C <sub>0</sub> (KN)	C (KN)	C <sub>0</sub> (KN)
20	29	35	12	16	33	59	61	101	77	128
25	35.5	42	16	20	53	97	99	165	126	210
30	40.7	47	18	22	69	125	127	213	163	270
35	47	55	20	25	88	160	164	274	209	347
40	53	62	22	28	110	198	203	339	259	430
45	60	68	25	32	141	255	261	437	333	554
50	66	75	28	35	174	314	322	538	410	682
60	80	90	36	44	271	490	501	838	639	1,063
70	92	105	40	49	346	626	640	1,071	817	1,358
80	105	120	45	55	444	803	822	1,375	1,049	1,744
90	115	130	50	60	541	978	1,001	1,673	1,277	2,122
100	130	150	55	70	672	1,216	1,244	2,081	1,587	2,638
110	140	160	55	70	724	1,309	1,340	2,241	1,709	2,841
120	160	180	70	85	1,053	1,904	1,949	3,259	2,486	4,133
140	180	210	70	90	1,184	2,142	2,192	3,667	2,797	4,649
160	200	230	80	105	1,504	2,720	2,784	4,656	3,552	5,904
180	225	260	80	105	1,692	3,060	3,132	5,238	3,996	6,642
200	250	290	100	130	2,350	4,250	4,350	7,275	5,550	9,225
220	275	320	100	135	2,585	4,675	4,785	8,003	6,105	10,148
240	300	340	100	140	2,820	5,100	5,220	8,730	6,660	11,070
260	325	370	110	150	3,361	6,078	6,221	10,403	7,937	13,192
280	350	400	120	155	3,948	7,140	7,308	12,222	9,324	15,498
300	375	430	120	165	4,230	7,650	7,830	13,095	9,990	16,605
320	380	440	135	160	4,822	8,721	8,926	14,928	11,389	18,930
340	400	460	135	160	5,076	9,180	9,396	15,714	11,988	19,926
360	420	480	135	160	5,330	9,639	9,866	16,500	12,587	20,922
380	450	520	160	190	6,768	12,240	12,528	20,952	15,984	26,568
400	470	540	160	190	7,069	12,784	13,085	21,883	16,694	27,749
420	490	560	160	190	7,370	13,328	13,642	22,814	17,405	28,930
440	520	600	185	218	9,043	16,354	16,739	27,994	21,356	35,498
460	540	620	185	218	9,391	16,983	17,383	29,071	22,178	36,863
480	565	650	195	230	10,356	18,730	19,170	32,061	24,459	40,655
500	585	670	195	230	10,723	19,393	19,849	33,196	25,325	42,094
530	620	710	205	243	11,947	21,607	22,115	36,986	28,216	46,900
560	655	750	215	258	13,238	23,940	24,504	40,980	31,263	51,964
600	700	800	230	272	15,134	27,370	28,014	46,851	35,742	59,409
630	740	850	260	300	18,086	32,708	33,478	55,988	42,713	70,996
670	785	900	260	308	19,185	34,697	35,513	59,393	45,310	75,313
710	830	950	275	325	21,456	38,803	39,716	66,421	50,672	84,224
750	875	1000	280	335	23,030	41,650	42,630	71,295	54,390	90,405
800	930	1060	300	355	26,226	47,430	48,546	81,189	61,938	102,951
850	985	1120	310	365	28,703	51,910	53,131	88,857	67,788	112,674
900	1040	1180	320	375	31,283	56,576	57,907	96,845	73,882	122,803
950	1100	1250	340	400	35,156	63,580	65,076	108,834	83,028	138,006
1000	1160	1320	370	438	40,345	72,964	74,681	124,897	95,282	158,375

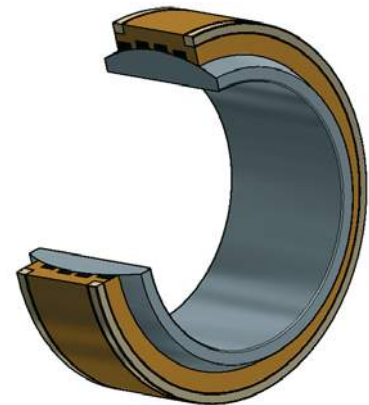
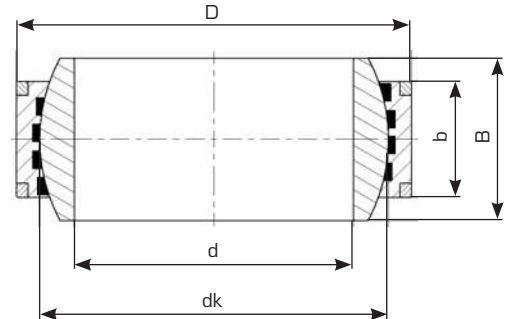

### FIXED BEARINGS ND type [FL]

The outer bearing ring is fixed with the housing and the bearing inner ring is fixed with the shaft. Rotational and tilting movement occurs on the spherical surface.

- Exists of a stainless steel inner ring and a LUB-MET® outer ring.
- Bronze alloy of LUB-MET® and grade of stainless steel will be recommended according to your application requirements
- Sea-water resistant material pairings are available
- Bearings can run completely without lubrication (self-lubricating)
- For contaminated applications, the bearing can be delivered with sealing and lubrication grooves
- Bearing size in this chart is compatible with standard "GE" bearings
- Custom bearings with greater tilting angles, higher load ratings, multiple force directions, etc. are possible

\*Alloy data sheets can be found on page 6

C = dynamic load rating

C<sub>0</sub> = static load rating

# LUB-MET® Spherical • Floating bearing

## HD series

Dimension (mm)					Load Rating HD LL					
					CuSn12		CuAl10Ni		CuZn25Al5	
d	dk	D	b	B	C (KN)	C <sub>0</sub> (KN)	C (KN)	C <sub>0</sub> (KN)	C (KN)	C <sub>0</sub> (KN)
100	135	150	67	71	860	1,556	1,593	2,664	2,032	3,378
110	145	160	74	78	1,021	1,846	1,889	3,160	2,411	4,007
120	160	180	80	85	1,218	2,202	2,254	3,769	2,876	4,780
140	185	210	95	100	1,672	3,024	3,095	5,176	3,948	6,563
160	210	230	109	115	2,177	3,938	4,031	6,741	5,143	8,548
180	240	260	122	128	2,785	5,037	5,156	8,623	6,578	10,934
200	260	290	134	140	3,314	5,994	6,135	10,260	7,827	13,010
220	290	320	148	155	4,083	7,384	7,558	12,640	9,643	16,028
240	310	340	162	170	4,777	8,640	8,843	14,789	11,283	18,754
260	340	370	175	185	5,660	10,236	10,477	17,522	13,368	22,219
280	370	400	190	200	6,687	12,094	12,379	20,703	15,794	26,252
300	390	430	200	212	7,420	13,419	13,735	22,970	17,524	29,127
320	414	460	218	230	8,585	15,527	15,892	26,578	20,276	33,703
340	434	480	230	243	9,496	17,173	17,577	29,396	22,426	37,276
360	474	520	243	258	10,957	19,816	20,282	33,920	25,877	43,012
380	494	540	258	272	12,124	21,927	22,443	37,534	28,634	47,594
400	514	580	265	280	12,957	23,434	23,985	40,113	30,601	50,865
420	534	600	280	300	14,224	25,723	26,329	44,032	33,592	55,835
440	574	630	300	315	16,381	29,625	30,322	50,712	38,687	64,304
460	593	650	308	325	17,375	31,422	32,161	53,787	41,034	68,204
480	623	680	320	340	18,965	34,298	35,105	58,710	44,789	74,447
500	643	710	335	355	20,491	37,058	37,930	63,435	48,394	80,438
530	673	750	355	375	22,728	41,103	42,070	70,359	53,676	89,218
560	723	800	380	400	26,135	47,266	48,378	80,909	61,724	102,596
600	773	850	400	425	29,414	53,195	54,446	91,057	69,466	115,464
630	813	900	425	450	32,869	59,444	60,843	101,754	77,627	129,029
670	862	950	450	475	36,900	66,734	68,305	114,233	87,147	144,853
710	912	1000	475	500	41,209	74,528	76,281	127,574	97,324	161,769
750	972	1060	500	530	46,232	83,611	85,579	143,123	109,187	181,486
800	1022	1120	530	565	51,527	93,187	95,380	159,515	121,692	202,271
850	1112	1220	565	600	59,767	108,089	110,633	185,023	141,152	234,617
900	1142	1250	600	635	65,182	117,882	120,655	201,786	153,940	255,873
950	1242	1360	635	670	75,025	135,683	138,875	232,257	177,186	294,511
1000	1312	1450	670	710	83,621	151,230	154,788	258,870	197,489	328,258

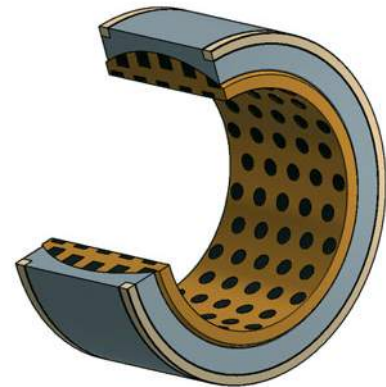
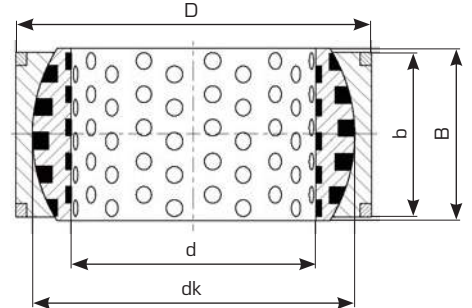

### FLOATING BEARINGS HD type [LL]

“HD” LUB-MET® bearings from SBS are designed for high-load applications, where space is limited.

The outer bearing ring is fixed with the housing. The spherical surface handles the tilting of the bearing and the rotational movement takes place at the inner diameter of the bearing and allows also for a longitudinal movement.

- Exists of a LUB-MET® inner ring and a stainless steel outer ring.
- Bronze alloy of LUB-MET® and grade of stainless steel will be recommended according to your application requirements
- Sea-water resistant material pairings are available
- Bearings can run completely without lubrication (self-lubricating)
- For contaminated applications, the bearing can be delivered with sealing and lubrication grooves
- Custom bearings with greater tilting angles, multiple force directions, etc. are possible

\*Alloy data sheets can be found on page 6

C = dynamic load rating

C<sub>0</sub> = static load rating



# LUB-MET® Spherical • Fixed bearing

## HD series

Dimension (mm)					Load Rating HD FL					
					CuSn12		CuAl10Ni		CuZn25Al5	
d	dk	D	b	B	C (KN)	C <sub>0</sub> (KN)	C (KN)	C <sub>0</sub> (KN)	C (KN)	C <sub>0</sub> (KN)
100	135	150	67	71	860	1,556	1,593	2,664	2,032	3,378
110	145	160	74	78	1,021	1,846	1,889	3,160	2,411	4,007
120	160	180	80	85	1,218	2,202	2,254	3,769	2,876	4,780
140	185	210	95	100	1,672	3,024	3,095	5,176	3,948	6,563
160	210	230	109	115	2,177	3,938	4,031	6,741	5,143	8,548
180	240	260	122	128	2,785	5,037	5,156	8,623	6,578	10,934
200	260	290	134	140	3,314	5,994	6,135	10,260	7,827	13,010
220	290	320	148	155	4,083	7,384	7,558	12,640	9,643	16,028
240	310	340	162	170	4,777	8,640	8,843	14,789	11,283	18,754
260	340	370	175	185	5,660	10,236	10,477	17,522	13,368	22,219
280	370	400	190	200	6,687	12,094	12,379	20,703	15,794	26,252
300	390	430	200	212	7,420	13,419	13,735	22,970	17,524	29,127
320	414	460	218	230	8,585	15,527	15,892	26,578	20,276	33,703
340	434	480	230	243	9,496	17,173	17,577	29,396	22,426	37,276
360	474	520	243	258	10,957	19,816	20,282	33,920	25,877	43,012
380	494	540	258	272	12,124	21,927	22,443	37,534	28,634	47,594
400	514	580	265	280	12,957	23,434	23,985	40,113	30,601	50,865
420	534	600	280	300	14,224	25,723	26,329	44,032	33,592	55,835
440	574	630	300	315	16,381	29,625	30,322	50,712	38,687	64,304
460	593	650	308	325	17,375	31,422	32,161	53,787	41,034	68,204
480	623	680	320	340	18,965	34,298	35,105	58,710	44,789	74,447
500	643	710	335	355	20,491	37,058	37,930	63,435	48,394	80,438
530	673	750	355	375	22,728	41,103	42,070	70,359	53,676	89,218
560	723	800	380	400	26,135	47,266	48,378	80,909	61,724	102,596
600	773	850	400	425	29,414	53,195	54,446	91,057	69,466	115,464
630	813	900	425	450	32,869	59,444	60,843	101,754	77,627	129,029
670	862	950	450	475	36,900	66,734	68,305	114,233	87,147	144,853
710	912	1000	475	500	41,209	74,528	76,281	127,574	97,324	161,769
750	972	1060	500	530	46,232	83,611	85,579	143,123	109,187	181,486
800	1022	1120	530	565	51,527	93,187	95,380	159,515	121,692	202,271
850	1112	1220	565	600	59,767	108,089	110,633	185,023	141,152	234,617
900	1142	1250	600	635	65,182	117,882	120,655	201,786	153,940	255,873
950	1242	1360	635	670	75,025	135,683	138,875	232,257	177,186	294,511
1000	1312	1450	670	710	83,621	151,230	154,788	258,870	197,489	328,258

\*Alloy data sheets can be found on page 6

C = dynamic load rating

C<sub>0</sub> = static load rating

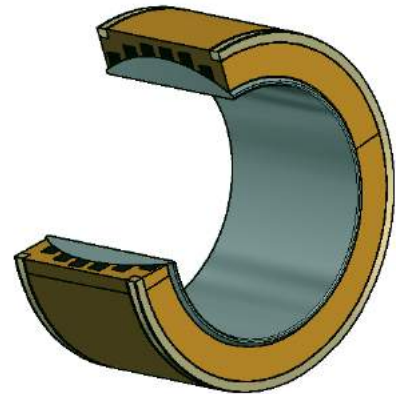
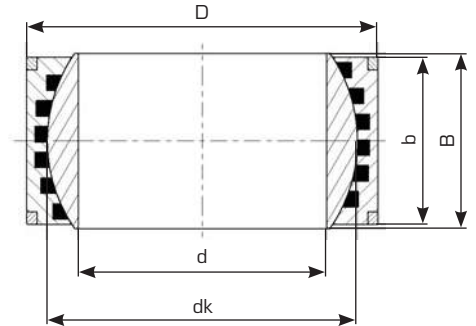

### FIXED BEARINGS HD type [FL]

“HD” LUB-MET® bearings from SBS are designed for high-load applications, where space is limited.

The outer bearing ring is fixed with the housing and the bearing inner ring is fixed with the shaft. Rotational and tilting movement occurs on the spherical surface.

- Exists of a stainless steel inner ring and a LUB-MET® outer ring.
- Bronze alloy of LUB-MET® and grade of stainless steel will be recommended according to your application requirements
- Sea-water resistant material pairings are available
- Bearings can run completely without lubrication (self-lubricating)
- For contaminated applications, the bearing can be delivered with sealing and lubrication grooves
- Custom bearings with greater tilting angles, multiple force directions, etc. are possible

# LUB-MET® Axial Spherical

## ND series

Dimension (mm)													CuAl10Ni		CuZn25Al5	
Product No.	d	D	T	B	C	D <sub>1</sub>	D <sub>a min</sub>	d <sub>2</sub>	d <sub>3</sub>	d <sub>a max</sub>	d <sub>K</sub>	α	Dyn. Load Rating Radial	Static. Load Rating Radial	Dyn. Load Rating Radial	Static. Load Rating Radial
													C (KN)	C <sub>0</sub> (KN)	C (KN)	C <sub>0</sub> (KN)
AX 10	10	30	9.5	7.9	6.0	16.5	18.5	27.5	21	21	32	10°	77	129	98	163
AX 12	12	35	13.0	9.3	9.0	19.5	21.5	32.0	24	24	37	9°	107	179	137	227
AX 15	15	42	15.0	10.7	11.0	24.0	26.0	38.9	29	29	45	7°	165	276	210	350
AX 17	17	47	16.0	11.5	11.5	28.0	30.5	43.4	34	34	50	6°	191	320	244	406
AX 20	20	55	20.0	14.3	13.0	33.5	38.0	50.0	40	40	60	6°	239	400	305	508
AX 25	25	62	22.5	16.0	17.0	34.5	39.0	57.5	45	45	66	7°	379	634	483	803
AX 30	30	75	26.0	18.0	19.5	44.0	49.0	69.0	56	56	80	6°	503	841	642	1,067
AX 35	35	90	28.0	22.0	20.0	52.0	57.0	84.0	66	66	98	6°	750	1,254	957	1,590
AX 40	40	105	32.0	27.0	22.0	59.0	65.0	98.0	78	78	114	6°	1,059	1,772	1,352	2,247
AX 45	45	120	36.5	31.0	25.0	68.0	74.0	112.0	89	89	130	6°	1,386	2,318	1,768	2,939
AX 50	50	130	42.5	33.5	32.0	69.0	75.0	122.5	98	98	140	5°	1,760	2,944	2,246	3,733
AX 60	60	150	45.0	37.0	33.0	86.0	92.0	140.0	108	108	160	7°	2,187	3,657	2,790	4,637
AX 70	70	160	50.0	40.0	36.0	95.0	102.0	149.5	121	121	170	6°	2,416	4,041	3,083	5,124
AX 80	80	180	50.0	42.0	36.0	108.0	115.0	168.0	130	130	194	6°	2,969	4,966	3,788	6,297
AX 100	100	210	59.0	50.0	42.0	133.0	141.0	195.5	155	155	220	7°	3,969	6,637	5,063	8,416
AX 120	120	230	64.0	52.0	45.0	154.0	162.0	214.0	170	170	245	8°	4,420	7,391	5,639	9,373
AX 140	140	260	72.0	61.0	50.0	176.0	187.0	244.0	198	198	272	6°	5,799	9,698	7,398	12,297
AX 160	160	290	77.0	65.0	52.0	199.0	211.0	272.0	213	213	310	7°	6,778	11,336	8,648	14,375
AX 180	180	320	86.0	70.0	60.0	224.0	236.0	300.0	240	240	335	8°	8,057	13,475	10,280	17,087
AX 200	200	340	87.0	74.0	60.0	246.0	259.0	321.0	265	265	358	8°	9,198	15,382	11,735	19,506

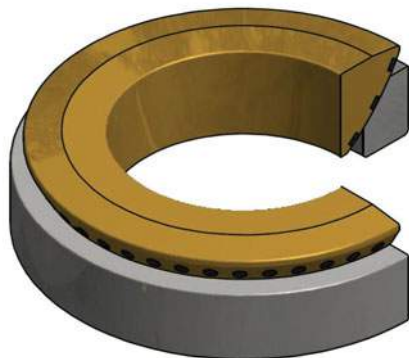
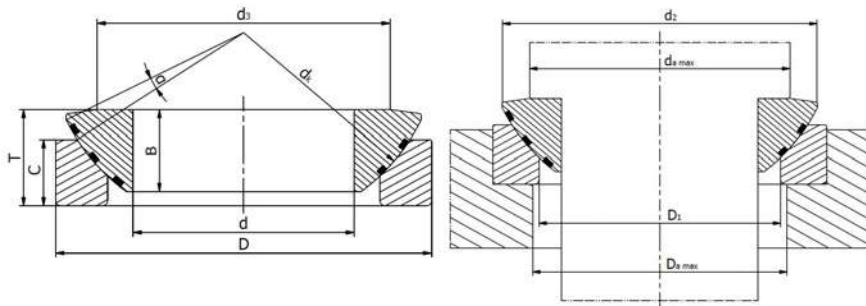

- Exists of a LUB-MET® inner ring and a stainless steel outer ring.
- Bronze alloy of LUB-MET® and grade of stainless steel will be recommended according to your application requirements
- Sea-water resistant material pairings are available
- Bearings can run completely without lubrication (self-lubricating)
- Bearing size in this chart is compatible with standard "GE" bearings
- Custom bearings with greater tilting angles, higher load ratings, etc. are possible

# SPHERICAL PLAIN BEARINGS & ROD ENDS



ball joint ends - spherical plain bearings  
maintenance-free and heavy-maintenance

# Spherical plain bearings

Requiring maintenance

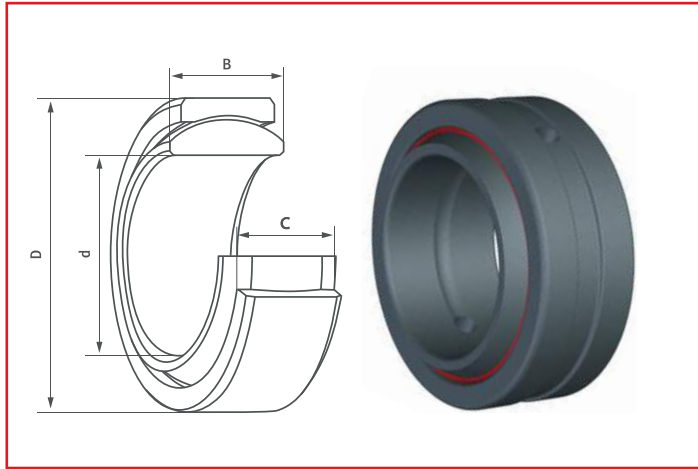

# Spherical plain bearings

Requiring maintenance

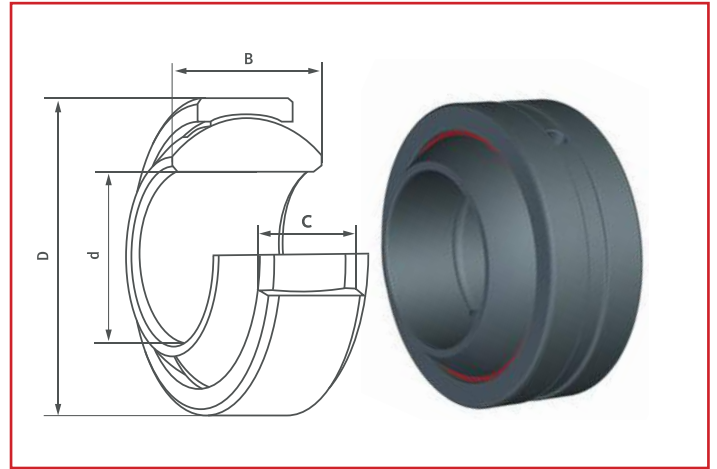

Spherical plain bearings, steel/steel

Art. Nr.		d	D	B	C	Load ratings [kN]	
						C	C <sub>0</sub>
GE 6 E	GE 6 DO	6	14	6	4	3.3	16.3
GE 8 E	GE 8 DO	8	16	8	5	5.3	26.4
GE 10 E	GE 10 DO	10	19	9	6	7.8	38.9
GE 12 E	GE 12 DO	12	22	10	7	10.4	52
GE 15 ES	GE 15 DO	15	26	12	9	16.3	82
GE 16 ES	GE 16 DO	16	30	14	10	20.4	102
GE 17 ES	GE 17 DO	17	30	14	10	20.4	102
GE 20 ES	GE 20 DO	20	35	16	12	28.8	140
GE 25 ES	GE 25 DO	25	42	20	16	46	230
GE 30 ES	GE 30 DO	30	47	22	18	60	298
GE 35 ES	GE 35 DO	35	55	25	20	77	384
GE 40 ES	GE 40 DO	40	62	28	22	96	480
GE 45 ES	GE 45 DO	45	68	32	25	122	614
GE 50 ES	GE 50 DO	50	75	35	28	150	749
GE 60 ES	GE 60 DO	60	90	44	36	235	1171
GE 70 ES	GE 70 DO	70	105	49	40	302	1498
GE 80 ES	GE 80 DO	80	120	55	45	384	1920
GE 90 ES	GE 90 DO	90	130	60	50	470	2352
GE 100 ES	GE 100 DO	100	150	70	55	586	2928
GE 110 ES	GE 110 DO	110	160	70	55	629	3120
GE 120 ES	GE 120 DO	120	180	85	70	912	4560
GE 140 ES	GE 140 DO	140	210	90	70	1037	5184
GE 160 ES	GE 160 DO	160	230	105	80	1315	6528
GE 180 ES	GE 180 DO	180	260	105	80	1469	7344
GE 200 ES	GE 200 DO	200	290	130	100	2035	10176
GE 220 ES	GE 220 DO	220	320	135	100	2227	11136
GE 240 ES	GE 240 DO	240	340	140	100	2448	12192
GE 260 ES	GE 260 DO	260	370	150	110	2928	14688
GE 280 ES	GE 280 DO	280	400	155	120	3408	17280
GE 300 ES	GE 300 DO	300	430	165	120	3648	18240

Spherical plain bearings, steel/steel, with wider inner ring

Art. Nr.		d	D	B	C	Load ratings [kN]	
						C	C <sub>0</sub>
GEH 6 E	GE 6 FO	6	16	9	5	5.3	26.4
GEH 8 E	GE 8 FO	8	19	11	6	7.8	38.9
GEH 10 E	GE 10 FO	10	22	12	7	10.4	52
GEH 12 E	GE 12 FO	12	26	15	9	16.3	82
GEH 15 ES	GE 15 FO	15	30	16	10	20.4	102
GEH 17 ES	GE 17 FO	17	35	20	12	28.8	140
GEH 20 ES	GE 20 FO	20	42	25	16	46	230
GEH 25 ES	GE 25 FO	25	47	28	18	60	298
GEH 30 ES	GE 30 FO	30	55	32	20	77	384
GEH 35 ES	GE 35 FO	35	62	35	22	96	480
GEH 40 ES	GE 40 FO	40	68	40	25	122	614
GEH 45 ES	GE 45 FO	45	75	43	28	150	749
GEH 50 ES	GE 50 FO	50	90	56	36	235	1171
GEH 60 ES	GE 60 FO	60	105	63	40	302	1498
GEH 70 ES	GE 70 FO	70	120	70	45	384	1920
GEH 80 ES	GE 80 FO	80	130	75	50	470	2352
GEH 90 ES	GE 90 FO	90	150	85	55	586	2928
GEH 100 ES	GE 100 FO	100	160	85	55	629	3120
GEH 110 ES	GE 110 FO	110	180	100	70	912	4560
GEH 120 ES	GE 120 FO	120	210	115	70	1037	5184
GEH 140 ES	GE 140 FO	140	230	130	80	1315	6528
GEH 160 ES	GE 160 FO	160	260	135	80	1469	7344
GEH 180 ES	GE 180 FO	180	290	155	100	2035	10176
GEH 200 ES	GE 200 FO	200	320	165	100	2227	11136
GEH 220 ES	GE 220 FO	220	340	175	100	2448	12192
GEH 240 ES	GE 240 FO	240	370	190	110	2928	14688
GEH 260 ES	GE 260 FO	260	400	205	120	3408	17280
GEH 280 ES	GE 280 FO	280	430	210	120	3648	18240

Spherical plain bearings, steel/steel with sealing

Art. Nr.		d	D	B	C	Load ratings [kN]	
						C	C <sub>0</sub>
GE 15 ES 2RS	GE 15 DO 2RS	15	26	12	9	16.3	82
GE 17 ES 2RS	GE 17 DO 2RS	17	30	14	10	20.4	102
GE 20 ES 2RS	GE 20 DO 2RS	20	35	16	12	28.8	140
GE 25 ES 2RS	GE 25 DO 2RS	25	42	20	16	46	230
GE 30 ES 2RS	GE 30 DO 2RS	30	47	22	18	60	298
GE 35 ES 2RS	GE 35 DO 2RS	35	55	25	20	77	384
GE 40 ES 2RS	GE 40 DO 2RS	40	62	28	22	96	480
GE 45 ES 2RS	GE 45 DO 2RS	45	68	32	25	122	614
GE 50 ES 2RS	GE 50 DO 2RS	50	75	35	28	150	749
GE 60 ES 2RS	GE 60 DO 2RS	60	90	44	36	235	1171
GE 70 ES 2RS	GE 70 DO 2RS	70	105	49	40	302	1498
GE 80 ES 2RS	GE 80 DO 2RS	80	120	55	45	384	1920
GE 90 ES 2RS	GE 90 DO 2RS	90	130	60	50	470	2352
GE 100 ES 2RS	GE 100 DO 2RS	100	150	70	55	586	2928
GE 110 ES 2RS	GE 110 DO 2RS	110	160	70	55	629	3120
GE 120 ES 2RS	GE 120 DO 2RS	120	180	85	70	912	4560
GE 140 ES 2RS	GE 140 DO 2RS	140	210	90	70	1037	5184
GE 160 ES 2RS	GE 160 DO 2RS	160	230	105	80	1315	6528
GE 180 ES 2RS	GE 180 DO 2RS	180	260	105	80	1469	7344
GE 200 ES 2RS	GE 200 DO 2RS	200	290	130	100	2035	10176
GE 220 ES 2RS	GE 220 DO 2RS	220	320	135	100	2227	11136
GE 240 ES 2RS	GE 240 DO 2RS	240	340	140	100	2448	12192
GE 260 ES 2RS	GE 260 DO 2RS	260	370	150	110	2928	14688
GE 280 ES 2RS	GE 280 DO 2RS	280	400	155	120	3408	17280
GE 300 ES 2RS	GE 300 DO 2RS	300	430	165	120	3648	18240

Spherical plain bearings, steel/steel, with wider inner ring and sealing

Art. Nr.		d	D	B	C	Load ratings [kN]	
						C	C <sub>0</sub>
GEH 15 ES 2RS	GE 15 FO 2RS	15	30	16	10	20.4	102
GEH 17 ES 2RS	GE 17 FO 2RS	17	35	20	12	28.8	140
GEH 20 ES 2RS	GE 20 FO 2RS	20	42	25	16	46	230
GEH 25 ES 2RS	GE 25 FO 2RS	25	47	28	18	60	298
GEH 30 ES 2RS	GE 30 FO 2RS	30	55	32	20	77	384
GEH 35 ES 2RS	GE 35 FO 2RS	35	62	35	22	96	480
GEH 40 ES 2RS	GE 40 FO 2RS	40	68	40	25	122	614
GEH 45 ES 2RS	GE 45 FO 2RS	45	75	43	28	150	749
GEH 50 ES 2RS	GE 50 FO 2RS	50	90	56	36	235	1171
GEH 60 ES 2RS	GE 60 FO 2RS	60	105	63	40	302	1498
GEH 70 ES 2RS	GE 70 FO 2RS	70	120	70	45	384	1920
GEH 80 ES 2RS	GE 80 FO 2RS	80	130	75	50	470	2352
GEH 90 ES 2RS	GE 90 FO 2RS	90	150	85	55	586	2928
GEH 100 ES 2RS	GE 100 FO 2RS	100	160	85	55	629	3120
GEH 110 ES 2RS	GE 110 FO 2RS	110	180	100	70	912	4560
GEH 120 ES 2RS	GE 120 FO 2RS	120	210	115	70	1037	5184
GEH 140 ES 2RS	GE 140 FO 2RS	140	230	130	80	1315	6528
GEH 160 ES 2RS	GE 160 FO 2RS	160	260	135	80	1469	7344
GEH 180 ES 2RS	GE 180 FO 2RS	180	290	155	100	2035	10176
GEH 200 ES 2RS	GE 200 FO 2RS	200	320	165	100	2227	11136
GEH 220 ES 2RS	GE 220 FO 2RS	220	340	175	100	2448	12192
GEH 240 ES 2RS	GE 240 FO 2RS	240	370	190	110	2928	14688
GEH 260 ES 2RS	GE 260 FO 2RS	260	400	205	120	3408	17280
GEH 280 ES 2RS	GE 280 FO 2RS	280	430	210	120	3648	18240

Permissible working temperature: -60°C - +130°C (Applications up to +200°C without sealings and from 150°C with possible losses of length of life). Further restrictions through lubricant should be kept in mind.

Permissible working temperature: -60°C - +130°C (Applications up to +200°C without sealings and from 150°C with possible losses of length of life). Further restrictions through lubricant should be kept in mind.

## Spherical plain bearings

Requiring maintenance

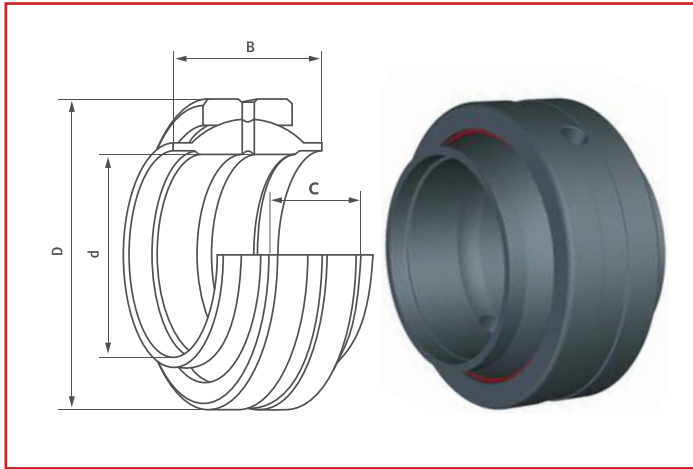

Spherical plain bearings, steel/steel,  
with wider inner ring

						Load ratings [kN]	
Art. Nr.		d	D	B	C	C	C <sub>0</sub>
GEG 12 ES	GE 12 LO	12	22	12	7	10.368	51.84
GEG 16 ES	GE 16 LO	16	28	16	9	16.896	84.48
GEG 20 ES	GE 20 LO	20	35	20	12	29	140
GEG 25 ES	GE 25 LO	25	42	25	16	46	230
GEG 30 ES	GE 30 LO	30	47	30	18	60	298
GEG 32 ES	GE 32 LO	32	52	32	18	65.5	312
GEG 35 ES	GE 35 LO	35	55	35	20	77	384
GEG 40 ES	GE 40 LO	40	62	40	22	96	480
GEG 45 ES	GE 45 LO	45	68	40	25	122	614
GEG 50 ES	GE 50 LO	50	75	50	28	150	749
GEG 60 ES	GE 60 LO	60	90	54	36	235	1171
GEG 63 ES	GE 63 LO	63	95	63	36	244.8	1219.2
GEG 70 ES	GE 70 LO	70	105	65	40	302	1498
GEG 80 ES	GE 80 LO	80	120	80	45	384	1920
GEG 90 ES	GE 90 LO	90	130	90	50	470.4	2352
GEG 100 ES	GE 100 LO	100	150	100	55	585.6	2928
GEG 110 ES	GE 110 LO	110	160	110	55	628.8	3120
GEG 125 ES	GE 125 LO	125	180	125	70	912	4560
GEG 160 ES	GE 160 LO	160	230	160	80	1315.2	6528
GEG 200 ES	GE 200 LO	200	290	200	100	2035.2	10176
GEG 250 ES	GE 250 LO	250	400	250	120	3408	17280
GEG 320 ES	GE 320 LO	320	520	320	160	5856	29280

Spherical plain bearings, steel/steel,  
with wider inner ring and sealing

						Load ratings [kN]	
Art. Nr.		d	D	B	C	C	C <sub>0</sub>
GEM 20 ES 2RS	GE 20 HO 2RS	20	35	24	12	29	140
GEM 25 ES 2RS	GE 25 HO 2RS	25	42	29	16	46	230
GEM 30 ES 2RS	GE 30 HO 2RS	30	47	30	18	60	298
GEM 35 ES 2RS	GE 35 HO 2RS	35	55	35	20	77	384
GEM 40 ES 2RS	GE 40 HO 2RS	40	62	38	22	96	480
GEM 45 ES 2RS	GE 45 HO 2RS	45	68	40	25	122	614
GEM 50 ES 2RS	GE 50 HO 2RS	50	75	43	28	150	749
GEM 60 ES 2RS	GE 60 HO 2RS	60	90	54	36	235	1171
GEM 70 ES 2RS	GE 70 HO 2RS	70	105	65	40	302	1498
GEM 80 ES 2RS	GE 80 HO 2RS	80	120	74	45	384	1920

## Spherical plain bearings

Requiring maintenance

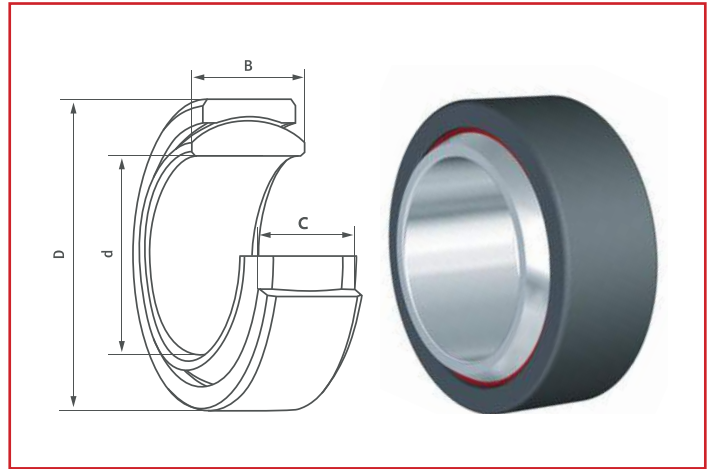

Spherical plain bearings,  
hard chrome plated/PTFE

						Load ratings [kN]	
Art. Nr.		d	D	B	C	C	C <sub>0</sub>
GE 6 UK	GE 6 C	6	14	6	4	3.5	8.6
GE 8 UK	GE 8 C	8	16	8	5	5.6	14
GE 10 UK	GE 10 C	10	19	9	6	8.3	21
GE 12 UK	GE 12 C	12	22	10	7	10.9	27
GE 15 UK	GE 15 C	15	26	12	9	17.3	43
GE 17 UK	GE 17 C	17	30	14	10	21.5	54
GE 20 UK	GE 20 C	20	35	16	12	30	75
GE 25 UK	GE 25 C	25	42	20	16	49	122
GE 30 UK	GE 30 C	30	47	22	18	63	159

Spherical plain bearings,  
hard chrome plated/PTFE with sealing

						Load ratings [kN]	
Art. Nr.		d	D	B	C	C	C <sub>0</sub>
GE 20 UK 2RS	GE 20 TE 2RS	20	35	16	12	67.5	112
GE 25 UK 2RS	GE 25 TE 2RS	25	42	20	16	127	212
GE 30 UK 2RS	GE 30 TE 2RS	30	47	22	18	165	275
GE 35 UK 2RS	GE 35 TE 2RS	35	55	25	20	210	350
GE 40 UK 2RS	GE 40 TE 2RS	40	62	28	22	277	462
GE 45 UK 2RS	GE 45 TE 2RS	45	68	32	25	360	600
GE 50 UK 2RS	GE 50 TE 2RS	50	75	35	28	442	737
GE 60 UK 2RS	GE 60 TE 2RS	60	90	44	36	690	1150
GE 70 UK 2RS	GE 70 TE 2RS	70	105	49	40	885	1475
GE 80 UK 2RS	GE 80 TE 2RS	80	120	55	45	1125	1875
GE 90 UK 2RS	GE 90 TE 2RS	90	130	60	50	1380	2300
GE 100 UK 2RS	GE 100 TE 2RS	100	150	70	55	1717	2862
GE 110 UK 2RS	GE 110 TE 2RS	110	160	70	55	1845	3075
GE 120 UK 2RS	GE 120 TE 2RS	120	180	85	70	2685	4475
GE 140 UK 2RS	GE 140 TA 2RS	140	210	90	70	3015	5025
GE 160 UK 2RS	GE 160 TA 2RS	160	230	105	80	3840	6400
GE 180 UK 2RS	GE 180 TA 2RS	180	260	105	80	4320	7200
GE 200 UK 2RS	GE 200 TA 2RS	200	290	130	100	6000	10000
GE 220 UK 2RS	GE 220 TA 2RS	220	320	135	100	6600	11000
GE 240 UK 2RS	GE 240 TA 2RS	240	340	140	100	7200	12000
GE 260 UK 2RS	GE 260 TA 2RS	260	370	150	110	8550	14250
GE 280 UK 2RS	GE 280 TA 2RS	280	400	155	120	10050	16750
GE 300 UK 2RS	GE 300 TA 2RS	300	430	165	120	10080	18000

Permissible working temperature: -60°C - +130°C (Applications up to +200°C without sealings and from 150°C with possible losses of length of life). Further restrictions through lubricant should be kept in mind.

Permissible working temperature: -50°C - +95°C (Applications up to +200°C with possible losses of length of life).

# Rod ends

Requiring maintenance

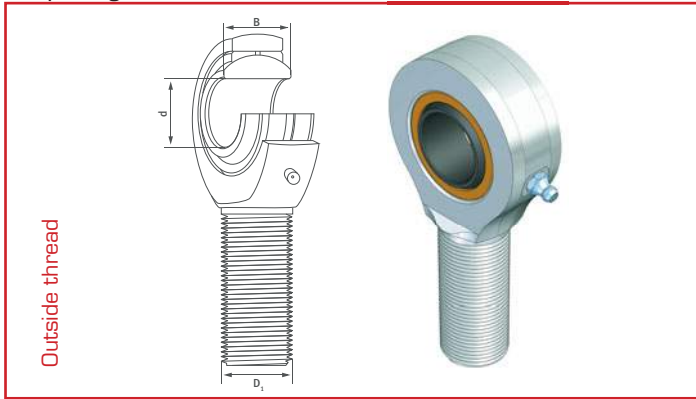

# Rod ends

Maintenance-bound

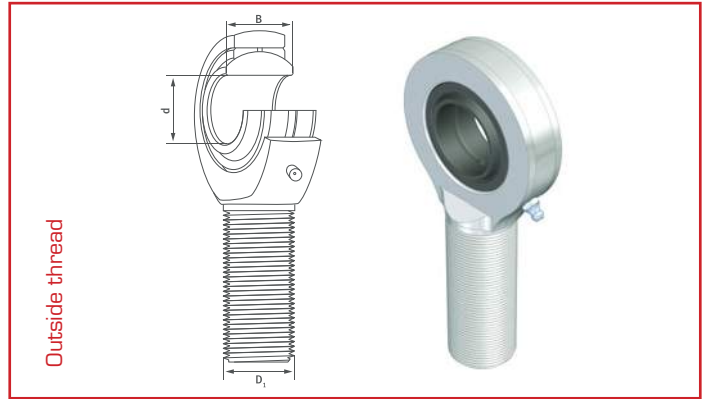

Rod end, steel / bronze with outside thread

Art. Nr.		d	B	D <sub>1</sub>
GAKFR 5 PB	(SAKAC 5 M)	5	8	M5
GAKFR 6 PB	(SAKAC 6 M)	6	9	M6
GAKFR 8 PB	(SAKAC 8 M)	8	12	M8
GAKFR 10 PB	(SAKAC 10 M)	10	14	M10
GAKFR 12 PB	(SAKAC 12 M)	12	16	M12
GAKFR 14 PB	(SAKAC 14 M)	14	19	M14
GAKFR 16 PB	(SAKAC 16 M)	16	21	M16
GAKFR 17 PB	(SAKAC 17 M)	17	22	M17
GAKFR 18 PB	(SAKAC 18 M)	18	23	M18 x 1,5
GAKFR 20 PB	(SAKAC 20 M)	20	25	M20 x 1,5
GAKFR 22 PB	(SAKAC 22 M)	22	28	M22 x 1,5
GAKFR 25 PB	(SAKAC 25 M)	25	31	M24 x 2
GAKFR 28 PB	(SAKAC 28 M)	28	35	M27 x 2
GAKFR 30 PB	(SAKAC 30 M)	30	37	M30 x 2

Rod end, steel / steel with outside thread

Art. Nr.		d	B	D <sub>1</sub>
GAR 6 DO	(SA 6 ES)	6	6	M6
GAR 8 DO	(SA 8 ES)	8	8	M8
GAR 10 DO	(SA 10 ES)	10	9	M10
GAR 12 DO	(SA 12 ES)	12	10	M12
GAR 15 DO	(SA 15 ES)	15	12	M14
GAR 17 DO	(SA 17 ES)	17	14	M16
GAR 20 DO	(SA 20 ES)	20	16	M20 x 1,5
GAR 25 DO	(SA 25 ES)	25	20	M24 x 2
GAR 30 DO	(SA 30 ES)	30	22	M30 x 2
GAR 35 DO	(SAA 35 ES)	35	25	M36 x 3
GAR 40 DO	(SAA 40 ES)	40	28	M39 x 3
GAR 45 DO	(SAA 45 ES)	45	32	M42 x 3
GAR 50 DO	(SAA 50 ES)	50	35	M45 x 3
GAR 60 DO	(SAA 60 ES)	60	44	M52 x 3
GAR 70 DO	(SAA 70 ES)	70	49	M56 x 4
GAR 80 DO	(SAA 80 ES)	80	55	M64 x 4

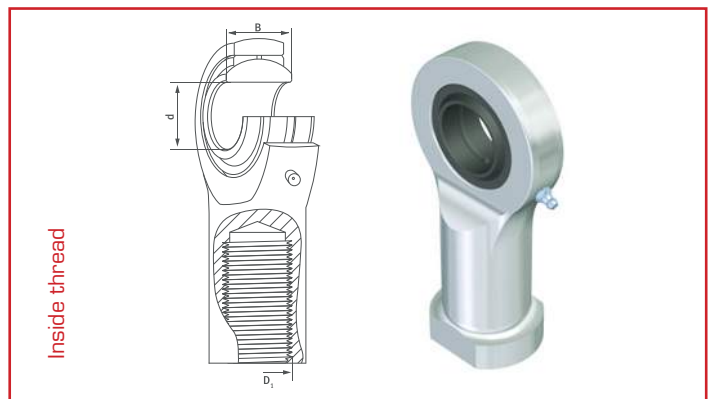
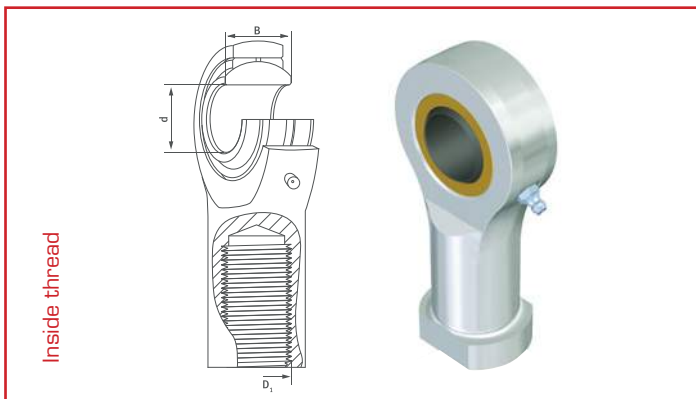

Rod end, steel / bronze with inside thread

Art. Nr.		d	B	D <sub>1</sub>
GIKFR 5 PB	(SIKAC 5 M)	5	8	M5
GIKFR 6 PB	(SIKAC 6 M)	6	9	M6
GIKFR 8 PB	(SIKAC 8 M)	8	12	M8
GIKFR 10 PB	(SIKAC 10 M)	10	14	M10
GIKFR 12 PB	(SIKAC 12 M)	12	16	M12
GIKFR 14 PB	(SIKAC 14 M)	14	19	M14
GIKFR 16 PB	(SIKAC 16 M)	16	21	M16
GIKFR 17 PB	(SIKAC 17 M)	17	22	M17
GIKFR 18 PB	(SIKAC 18 M)	18	23	M18 x 1,5
GIKFR 20 PB	(SIKAC 20 M)	20	25	M20 x 1,5
GIKFR 22 PB	(SIKAC 22 M)	22	28	M22 x 1,5
GIKFR 25 PB	(SIKAC 25 M)	25	31	M24 x 2
GIKFR 28 PB	(SIKAC 28 M)	28	35	M27 x 2
GIKFR 30 PB	(SIKAC 30 M)	30	37	M30 x 2

Rod end, steel / steel with inside thread

Art. Nr.		d	B	D <sub>1</sub>
GIR 6 DO	(SI 6 ES)	6	6	M6
GIR 8 DO	(SI 8 ES)	8	8	M8
GIR 10 DO	(SI 10 ES)	10	9	M10
GIR 12 DO	(SI 12 ES)	12	10	M12
GIR 15 DO	(SI 15 ES)	15	12	M14
GIR 17 DO	(SI 17 ES)	17	14	M16
GIR 20 DO	(SI 20 ES)	20	16	M20 x 1,5
GIR 25 DO	(SI 25 ES)	25	20	M24 x 2
GIR 30 DO	(SI 30 ES)	30	22	M30 x 2
GIR 35 DO	(SIA 35 ES)	35	25	M36 x 3
GIR 40 DO	(SIA 40 ES)	40	28	M39 x 3
GIR 45 DO	(SIA 45 ES)	45	32	M42 x 3
GIR 50 DO	(SIA 50 ES)	50	35	M45 x 3
GIR 60 DO	(SIA 60 ES)	60	44	M52 x 3
GIR 70 DO	(SIA 70 ES)	70	49	M56 x 4
GIR 80 DO	(SIA 80 ES)	80	55	M64 x 4

Permissible working temperature: -60°C - +150°C  
 (Applications up to +250°C with possible losses of length of life).  
 Further restrictions through lubricant should be kept in mind.

Permissible working temperature: -60°C - +150°C  
 (Applications up to +250°C with possible losses of length of life).  
 Further restrictions through lubricant should be kept in mind.

## Rod ends

Requiring maintenance

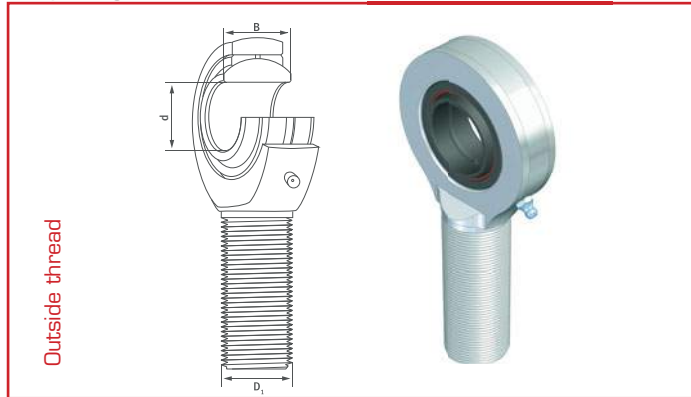

Rod end, steel / steel with outside thread and sealing

Art. Nr.		d	B	D <sub>1</sub>
GAR 15 DO 2RS	(SA 15 ES 2RS)	15	12	M14
GAR 17 DO 2RS	(SA 17 ES 2RS)	17	14	M16
GAR 20 DO 2RS	(SA 20 ES 2RS)	20	16	M20 x 1,5
GAR 25 DO 2RS	(SA 25 ES 2RS)	25	20	M24 x 2
GAR 30 DO 2RS	(SA 30 ES 2RS)	30	22	M30 x 2
GAR 35 DO 2RS	(SAA 35 ES 2RS)	35	25	M36 x 3
GAR 40 DO 2RS	(SAA 40 ES 2RS)	40	28	M39 x 3
GAR 45 DO 2RS	(SAA 45 ES 2RS)	45	32	M42 x 3
GAR 50 DO 2RS	(SAA 50 ES 2RS)	50	35	M45 x 3
GAR 60 DO 2RS	(SAA 60 ES 2RS)	60	44	M52 x 3
GAR 70 DO 2RS	(SAA 70 ES 2RS)	70	49	M56 x 4
GAR 80 DO 2RS	(SAA 80 ES 2RS)	80	55	M64 x 4

## Rod ends

Maintenance-free

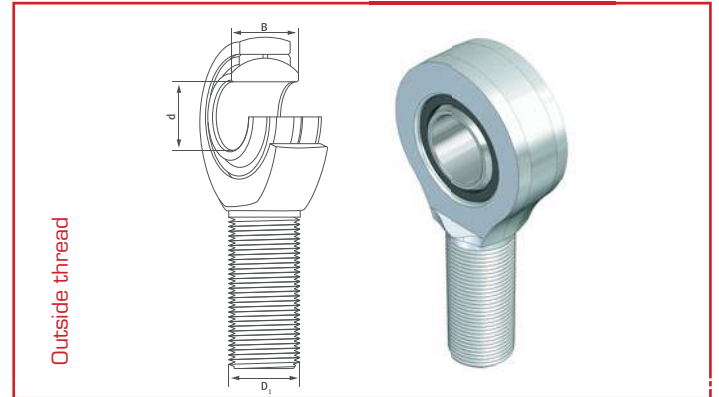

Rod end, steel / PTFE with outside thread

Art. Nr.		d	B	D <sub>1</sub>
GAKFR 5 PW	(SAKAC 5 F)	5	8	M5
GAKFR 6 PW	(SAKAC 6 F)	6	9	M6
GAKFR 8 PW	(SAKAC 8 F)	8	12	M8
GAKFR 10 PW	(SAKAC 10 F)	10	14	M10
GAKFR 12 PW	(SAKAC 12 F)	12	16	M12
GAKFR 14 PW	(SAKAC 14 F)	14	19	M14
GAKFR 16 PW	(SAKAC 16 F)	16	21	M16
GAKFR 17 PW	(SAKAC 17 F)	17	22	M17
GAKFR 18 PW	(SAKAC 18 F)	18	23	M18 x 1,5
GAKFR 20 PW	(SAKAC 20 F)	20	25	M20 x 1,5
GAKFR 22 PW	(SAKAC 22 F)	22	28	M22 x 1,5
GAKFR 25 PW	(SAKAC 25 F)	25	31	M24 x 2
GAKFR 28 PW	(SAKAC 28 F)	28	35	M27 x 2
GAKFR 30 PW	(SAKAC 30 F)	30	37	M30 x 2

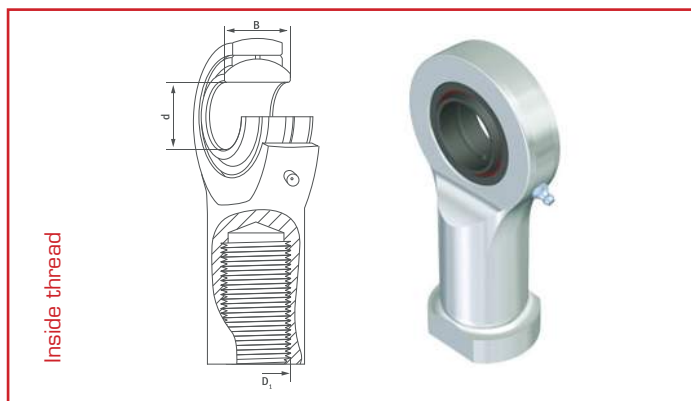

Rod end, steel / steel with inside thread and sealing

Art. Nr.		d	B	D <sub>1</sub>
GIR 15 DO 2RS	(SI 15 ES 2RS)	15	12	M14
GIR 17 DO 2RS	(SI 17 ES 2RS)	17	14	M16
GIR 20 DO 2RS	(SI 20 ES 2RS)	20	16	M20 x 1,5
GIR 25 DO 2RS	(SI 25 ES 2RS)	25	20	M24 x 2
GIR 30 DO 2RS	(SI 30 ES 2RS)	30	22	M30 x 2
GIR 35 DO 2RS	(SIA 35 ES 2RS)	35	25	M36 x 3
GIR 40 DO 2RS	(SIA 40 ES 2RS)	40	28	M39 x 3
GIR 45 DO 2RS	(SIA 45 ES 2RS)	45	32	M42 x 3
GIR 50 DO 2RS	(SIA 50 ES 2RS)	50	35	M45 x 3
GIR 60 DO 2RS	(SIA 60 ES 2RS)	60	44	M52 x 3
GIR 70 DO 2RS	(SIA 70 ES 2RS)	70	49	M56 x 4
GIR 80 DO 2RS	(SIA 80 ES 2RS)	80	55	M64 x 4

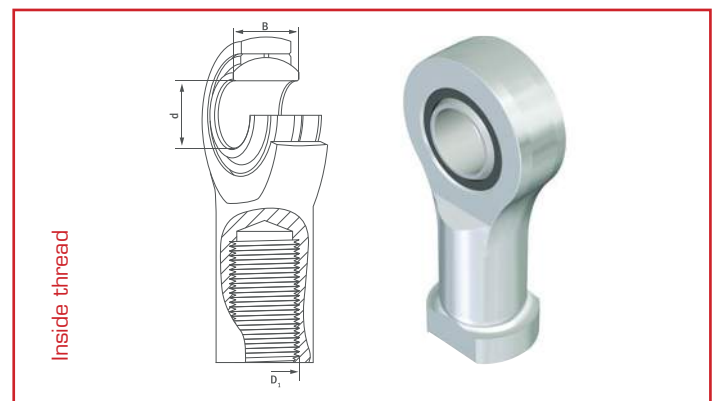

Rod end, steel / PTFE with inside thread

Art. Nr.		d	B	D <sub>1</sub>
GIKFR 5 PW	(SIKAC 5 F)	5	8	M5
GIKFR 6 PW	(SIKAC 6 F)	6	9	M6
GIKFR 8 PW	(SIKAC 8 F)	8	12	M8
GIKFR 10 PW	(SIKAC 10 F)	10	14	M10
GIKFR 12 PW	(SIKAC 12 F)	12	16	M12
GIKFR 14 PW	(SIKAC 14 F)	14	19	M14
GIKFR 16 PW	(SIKAC 16 F)	16	21	M16
GIKFR 17 PW	(SIKAC 17 F)	17	22	M17
GIKFR 18 PW	(SIKAC 18 F)	18	23	M18 x 1,5
GIKFR 20 PW	(SIKAC 20 F)	20	25	M20 x 1,5
GIKFR 22 PW	(SIKAC 22 F)	22	28	M22 x 1,5
GIKFR 25 PW	(SIKAC 25 F)	25	31	M24 x 2
GIKFR 28 PW	(SIKAC 28 F)	28	35	M27 x 2
GIKFR 30 PW	(SIKAC 30 F)	30	37	M30 x 2

Permissible working temperature: -60°C - +130°C [Applications up to +200°C without sealings and from 150°C with possible losses of length of life]. Further restrictions through lubricant should be kept in mind.

Permissible working temperature: -60°C - +100°C [Applications up to +200°C with possible losses of length of life].

# Rod ends

Maintenance-free

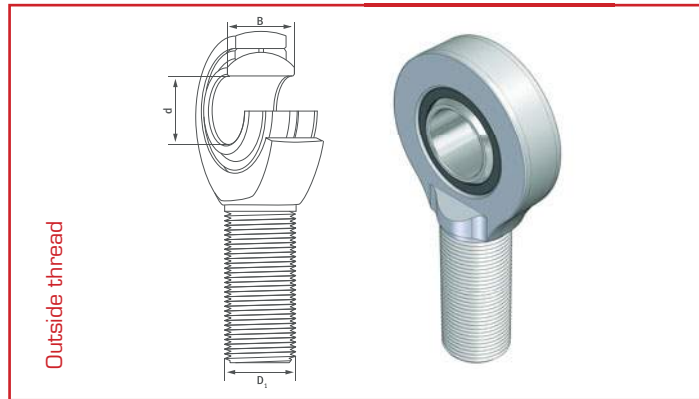

Rod end, hard chrome plated / PTFE with outside thread

Art. Nr.		d	B	D <sub>1</sub>
GAR 6 UK	(SA 6 C)	6	6	M6
GAR 8 UK	(SA 8 C)	8	8	M8
GAR 10 UK	(SA 10 C)	10	9	M10
GAR 12 UK	(SA 12 C)	12	10	M12
GAR 15 UK	(SA 15 C)	15	12	M14
GAR 17 UK	(SA 17 C)	17	14	M16
GAR 20 UK	(SA 20 C)	20	16	M20 x 1,5
GAR 25 UK	(SA 25 C)	25	20	M24 x 2
GAR 30 UK	(SA 30 C)	30	22	M30 x 2

# Rod ends

Maintenance-free

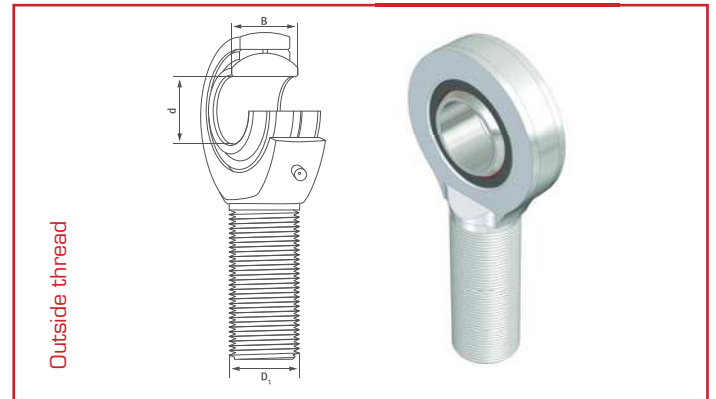

Rod end, hard chrome plated / PTFE with outside thread and sealing

Art. Nr.		d	B	D <sub>1</sub>
GAR 20 UK 2RS	(SA 20 TE 2RS)	20	16	M20 x 1,5
GAR 25 UK 2RS	(SA 25 TE 2RS)	25	20	M24 x 2
GAR 30 UK 2RS	(SA 30 TE 2RS)	30	22	M30 x 2
GAR 35 UK 2RS	(SAA 35 TE 2RS)	35	25	M36 x 3
GAR 40 UK 2RS	(SAA 40 TE 2RS)	40	28	M39 x 3
GAR 45 UK 2RS	(SAA 45 TE 2RS)	45	32	M42 x 3
GAR 50 UK 2RS	(SAA 50 TE 2RS)	50	35	M45 x 3
GAR 60 UK 2RS	(SAA 60 TE 2RS)	60	44	M52 x 3
GAR 70 UK 2RS	(SAA 70 TE 2RS)	70	49	M56 x 4
GAR 80 UK 2RS	(SAA 80 TE 2RS)	80	55	M64 x 4

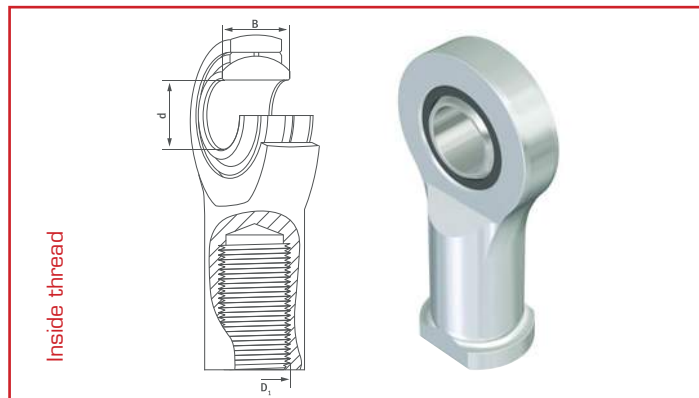

Rod end, hard chrome plated / PTFE with inside thread

Art. Nr.		d	B	D <sub>1</sub>
GIR 6 UK	(SI 6 C)	6	6	M6
GIR 8 UK	(SI 8 C)	8	8	M8
GIR 10 UK	(SI 10 C)	10	9	M10
GIR 12 UK	(SI 12 C)	12	10	M12
GIR 15 UK	(SI 15 C)	15	12	M14
GIR 17 UK	(SI 17 C)	17	14	M16
GIR 20 UK	(SI 20 C)	20	16	M20 x 1,5
GIR 25 UK	(SI 25 C)	25	20	M24 x 2
GIR 30 UK	(SI 30 C)	30	22	M30 x 2

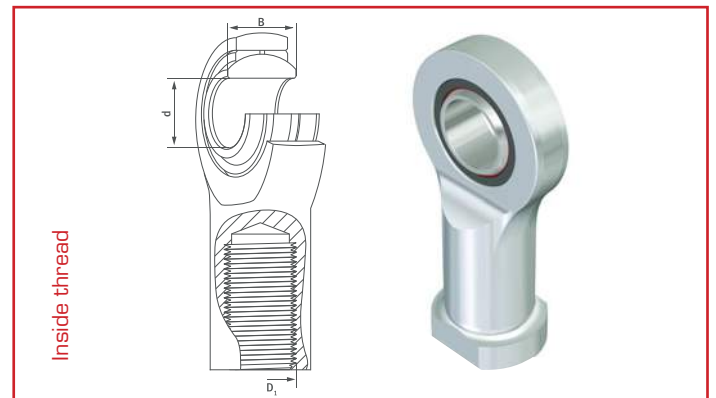

Rod end, hard chrome plated / PTFE with inside thread and sealing

Art. Nr.		d	B	D <sub>1</sub>
GIR 20 UK 2RS	(SA 20 TE 2RS)	20	16	M20 x 1,5
GIR 25 UK 2RS	(SA 25 TE 2RS)	25	20	M24 x 2
GIR 30 UK 2RS	(SA 30 TE 2RS)	30	22	M30 x 2
GIR 35 UK 2RS	(SAA 35 TE 2RS)	35	25	M36 x 3
GIR 40 UK 2RS	(SAA 40 TE 2RS)	40	28	M39 x 3
GIR 45 UK 2RS	(SAA 45 TE 2RS)	45	32	M42 x 3
GIR 50 UK 2RS	(SAA 50 TE 2RS)	50	35	M45 x 3
GIR 60 UK 2RS	(SAA 60 TE 2RS)	60	44	M52 x 3
GIR 70 UK 2RS	(SAA 70 TE 2RS)	70	49	M56 x 4
GIR 80 UK 2RS	(SAA 80 TE 2RS)	80	55	M64 x 4

Permissible working temperature: -60°C - +100°C  
(Applications up to +200°C with possible losses of length of life).

Permissible working temperature: -60°C - +100°C  
(Applications up to +200°C with possible losses of length of life).



## Hydraulic rod ends

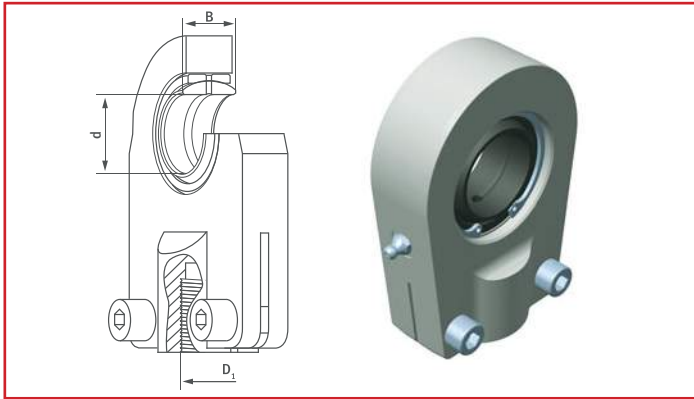

Hydraulic rod end, steel / steel with inside thread clampable

Art. Nr.		d	B	D <sub>1</sub>
GIHR-K 20 DO	(SIR 20 ES)	20	16	M16 x 1,5
GIHR-K 25 DO	(SIR 25 ES)	25	20	M16 x 1,5
GIHR-K 30 DO	(SIR 30 ES)	30	22	M22 x 1,5
GIHR-K 35 DO	(SIR 35 ES)	35	25	M28 x 1,5
GIHR-K 40 DO	(SIR 40 ES)	40	28	M35 x 1,5
GIHR-K 50 DO	(SIR 50 ES)	50	35	M45 x 1,5
GIHR-K 60 DO	(SIR 60 ES)	60	44	M58 x 1,5
GIHR-K 70 DO	(SIR 70 ES)	70	49	M65 x 1,5
GIHR-K 80 DO	(SIR 80 ES)	80	55	M80 x 2
GIHR-K 90 DO	(SIR 90 ES)	90	60	M100 x 2
GIHR-K 100 DO	(SIR 100 ES)	100	70	M110 x 2
GIHR-K 110 DO	(SIR 110 ES)	110	70	M120 x 2
GIHR-K 120 DO	(SIR 120 ES)	120	85	M130 x 2

## Hydraulic rod ends

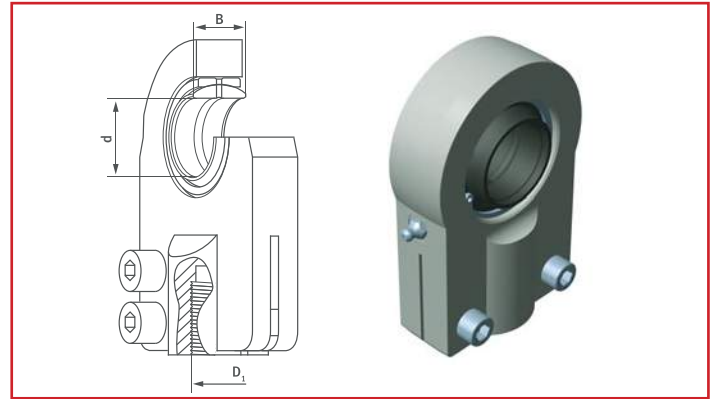

Hydraulic rod end, steel / steel with inside thread clampable

Art. Nr.		d	B	D <sub>1</sub>
GIHN-K 12 LO	(SIQG 12 ES)	12	12	M12 x 1,25
GIHN-K 16 LO	(SIQG 16 ES)	16	16	M14 x 1,5
GIHN-K 20 LO	(SIQG 20 ES)	20	20	M16 x 1,5
GIHN-K 25 LO	(SIQG 25 ES)	25	25	M20 x 1,5
GIHN-K 32 LO	(SIQG 32 ES)	32	32	M27 x 2
GIHN-K 40 LO	(SIQG 40 ES)	40	40	M33 x 2
GIHN-K 50 LO	(SIQG 50 ES)	50	50	M42 x 2
GIHN-K 63 LO	(SIQG 63 ES)	63	63	M48 x 2
GIHN-K 70 LO	(SIQG 70 ES)	70	70	M56 x 2
GIHN-K 80 LO	(SIQG 80 ES)	80	80	M64 x 2
GIHN-K 90 LO	(SIQG 90 ES)	90	90	M72 x 3
GIHN-K 100 LO	(SIQG 100 ES)	100	100	M80 x 3
GIHN-K 110 LO	(SIQG 110 ES)	110	110	M90 x 3
GIHN-K 125 LO	(SIQG 125 ES)	125	125	M100 x 3
GIHN-K 160 LO	(SIQG 160 ES)	160	160	M125x4
GIHN-K 200 LO	(SIQG 200 ES)	200	200	M160x4

Hydraulic rod end, steel / steel with inside thread non-clampable

Art. Nr.		d	B	D <sub>1</sub>
GIHR 20 DO	(SIRD 20 ES)	20	16	M16 x 1,5
GIHR 25 DO	(SIRD 25 ES)	25	20	M16 x 1,5
GIHR 30 DO	(SIRD 30 ES)	30	22	M22 x 1,5
GIHR 35 DO	(SIRD 35 ES)	35	25	M28 x 1,5
GIHR 40 DO	(SIRD 40 ES)	40	28	M35 x 1,5
GIHR 50 DO	(SIRD 50 ES)	50	35	M45 x 1,5
GIHR 60 DO	(SIRD 60 ES)	60	44	M58 x 1,5
GIHR 70 DO	(SIRD 70 ES)	70	49	M65 x 1,5
GIHR 80 DO	(SIRD 80 ES)	80	55	M80 x 2
GIHR 90 DO	(SIRD 90 ES)	90	60	M100 x 2
GIHR 100 DO	(SIRD 100 ES)	100	70	M110 x 2
GIHR 110 DO	(SIRD 110 ES)	110	70	M120 x 3
GIHR 120 DO	(SIRD 120 ES)	120	85	M130 x 3

Hydraulic rod end, steel / steel with inside thread clampable

Art. Nr.		d	B	D <sub>1</sub>
GIHO-K 12 DO	(SIJ 12 ES)	12	10	M10 x 1,25
GIHO-K 16 DO	(SIJ 16 ES)	16	14	M12 x 1,25
GIHO-K 20 DO	(SIJ 20 ES)	20	16	M14 x 1,5
GIHO-K 25 DO	(SIJ 25 ES)	25	20	M16 x 1,5
GIHO-K 30 DO	(SIJ 30 ES)	30	22	M20 x 1,5
GIHO-K 40 DO	(SIJ 40 ES)	40	28	M27 x 2
GIHO-K 50 DO	(SIJ 50 ES)	50	35	M33 x 2
GIHO-K 60 DO	(SIJ 60 ES)	60	44	M42 x 2
GIHO-K 80 DO	(SIJ 80 ES)	80	55	M48 x 2
GIHO-K 100 DO	(SIJ 100 ES)	100	70	M64 x 3

Permissible working temperature: -60°C - +150°C  
(Applications up to +250°C with possible losses of length of life).  
Further restrictions through lubricant should be kept in mind.

Permissible working temperature: -60°C - +150°C  
(Applications up to +250°C with possible losses of length of life).  
Further restrictions through lubricant should be kept in mind.

## Hydraulic rod ends

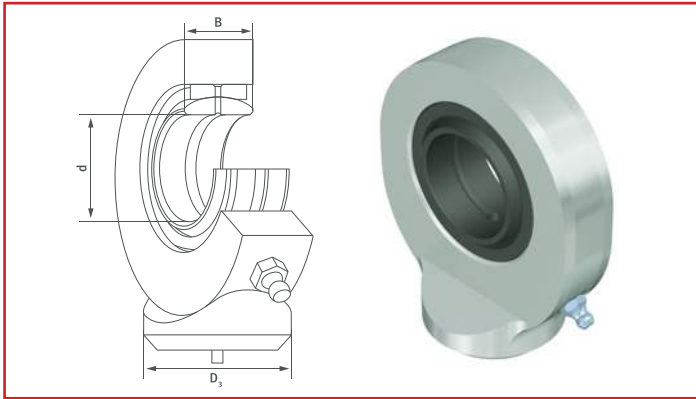

Hydraulic rod end, steel / steel with round weld-on bolt

Art. Nr.		d	B	D <sub>3</sub>
GK 10 DO	(SC 10 ES)	10	9	15,0
GK 12 DO	(SC 12 ES)	12	10	17,5
GK 15 DO	(SC 15 ES)	15	12	21,0
GK 17 DO	(SC 17 ES)	17	14	24,0
GK 20 DO	(SC 20 ES)	20	16	27,5
GK 25 DO	(SC 25 ES)	25	20	33,5
GK 30 DO	(SC 30 ES)	30	22	40,0
GK 35 DO	(SC 35 ES)	35	25	47,0
GK 40 DO	(SC 40 ES)	40	28	52,0
GK 45 DO	(SC 45 ES)	45	32	58,0
GK 50 DO	(SC 50 ES)	50	35	62,0
GK 60 DO	(SC 60 ES)	60	44	70,0
GK 70 DO	(SC 70 ES)	70	49	80,0
GK 80 DO	(SC 80 ES)	80	55	95,0

## Hydraulic rod ends

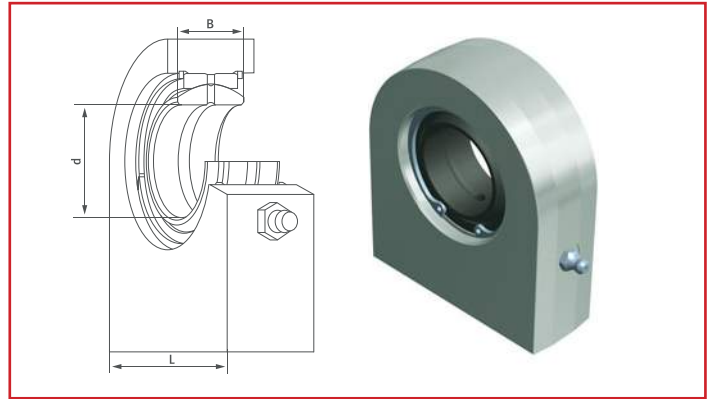

Hydraulic rod end, steel / steel with angular weld-on bolt

Art. Nr.		d	B	L
GF 20 DO	(SCF 20 ES )	20	16	50
GF 25 DO	(SCF 25 ES )	25	20	55
GF 30 DO	(SCF 30 ES )	30	22	65
GF 35 DO	(SCF 35 ES )	35	25	83
GF 40 DO	(SCF 40 ES )	40	28	100
GF 45 DO	(SCF 45 ES )	45	32	110
GF 50 DO	(SCF 50 ES )	50	35	123
GF 60 DO	(SCF 60 ES )	60	44	140
GF 70 DO	(SCF 70 ES )	70	49	164
GF 80 DO	(SCF 80 ES )	80	55	180
GF 90 DO	(SCF 90 ES )	90	60	226
GF 100 DO	(SCF 100 ES)	100	70	250
GF 110 DO	(SCF 110 ES)	110	70	295
GF 120 DO	(SCF 120 ES)	120	85	360

Permissible working temperature: -60°C - +150°C  
 (Applications up to +250°C with possible losses of length of life).  
 Further restrictions through lubricant should be kept in mind.

Permissible working temperature: -60°C - +150°C  
 (Applications up to +250°C with possible losses of length of life).  
 Further restrictions through lubricant should be kept in mind.

DAS CERTIFICATION



### Quality Management System Certificate of Approval

This is to certify that the QMS of  
**SBS-SINGA BEARINGS SOLUTIONS PTE LTD**

50 Bukit Batok Street 23  
#06-08 Midview Building  
Singapore 659578

Has been assessed and found to meet the requirements of

**ISO 9001:2015**

This certificate is valid for the following scope of operations:

**Trading of sliding bearings including technical support**

Authorised by 

**Ye Rouyan**  
Director

**Date of Certificate Issue: 29 August 2016**

**Certificate Valid Until: 28 August 2019**

Certified since 29 August 2016.

This certificate is the property of DAS Certification and remains valid subject to satisfactory annual surveillance audits.

**DAS Certification Singapore Pte Ltd**

33 Ubi Avenue 3  
#02-34 Vertex Tower A  
Singapore 408868  
Tel: (65) 6333 5023  
Email: [info@dascertsg.com](mailto:info@dascertsg.com)  
Web: [www.dascertsg.com](http://www.dascertsg.com)  
Company number: 200720506W

**Certificate Number: QS8004**



COM-KU®/D for Raiser Handling Winch System



LUB-MET® Spherical Bearings for Marina Barrage Gates



Barrage Hallein, Austria, COM-KU®/D Spherical ND 220 with seals

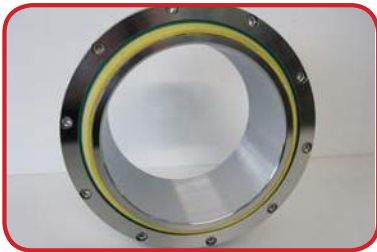

Theun Hinboun Expansion, Laos, LUB-MET®



Srinakarin power plant, Thailand, LUB-MET®



LUB-MET® flange bushings for Gypsy and Vertical Pins

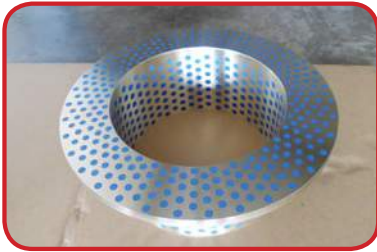

LUB-MET® Spherical Bearings GE 400 for Chain Stoppers

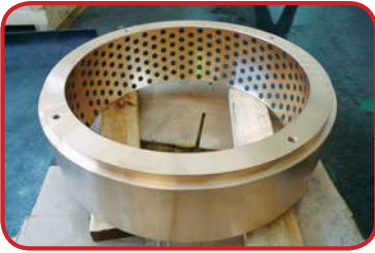

COM-KU®/D for Chain Stoppers, ID 280mm



COM-KU®/D Bushings for double-stroke Hydraulic Cylinder, Split Hopper Barge



FER-MAN® 259 & 246 for Main, Arm and Bucket Hinges of Backhoe Dredger



In-house design of LUB-MET® & COM-KU®/D Spherical combination, Guide Wheel



LUB-MET® with Seals and Customised Steel Housing for Underwater Sheaves

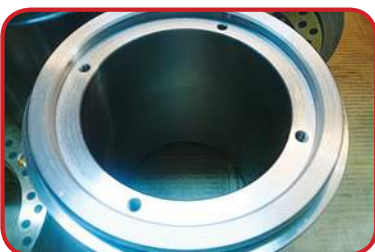

Xiangjiaba Hydro Dam: The second largest Shiplifter in the world



4 Trunnions with Ballpoint Ø of 400mm, OD 700, H 620 and 1500kg each



1,964 pcs of Bushings, Wearplates and special Spherical Axial Bearings



Made from GAP-MET®/N, GAP-MET®/M, LUB-MET® and BRO-MAS®

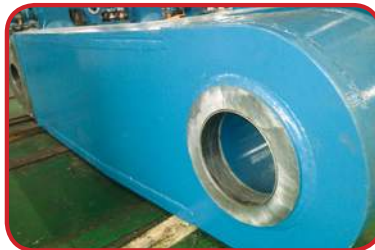

GAP-MET®/N with ID 610 and 820mm freeze fitted



and installed into the Alignment Equipment



**Some of our other projects:**

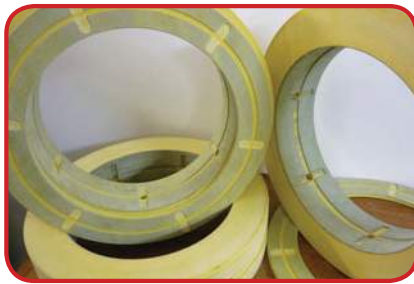
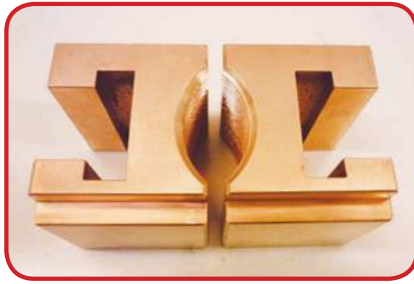
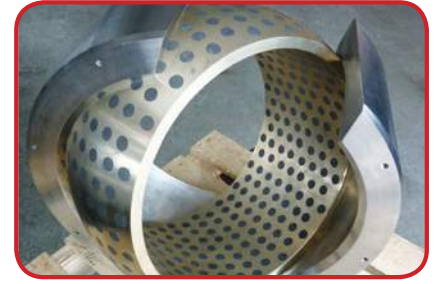
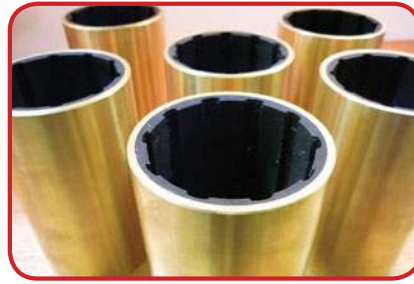
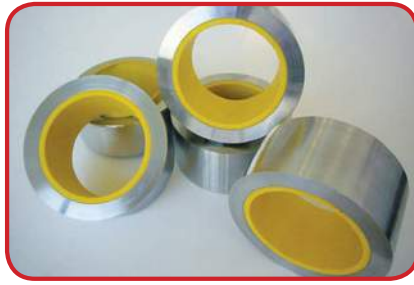

We are looking forward to hear from you!

## SINGAPORE

SBS - Singa Bearings Solutions® PTE. LTD.

50 Bukit Batok St. 23  
#06-08 Midview Bldg.  
Singapore 659578

☎ Tel.: +65 6316 3850  
Fax: +65 6316 3851

[www.sbs-bearings.com.sg](http://www.sbs-bearings.com.sg)  
[info@sbs-bearings.com.sg](mailto:info@sbs-bearings.com.sg)

## INDONESIA

PT. Singa Bearings Solutions

Garden Centre Level 5. R. 5-04B  
Cilandak Commercial Estate  
Jl. Raya Cilandak KKO  
Jakarta Selatan 12560  
Indonesia

☎ Tel.: +62 21 7891867  
Fax: +62 21 7891868

[www.sbs-bearings.com.sg](http://www.sbs-bearings.com.sg)  
[info.indo@sbs-bearings.com.sg](mailto:info.indo@sbs-bearings.com.sg)



SBS - Singa Bearings Solutions® PTE. LTD. is ISO 9001:2015 certified